

GENERAC[®]

MAGNUM

Owner's Manual

Light Tower

MLT6SM • MLT6SK

S/N 3002908801 and above

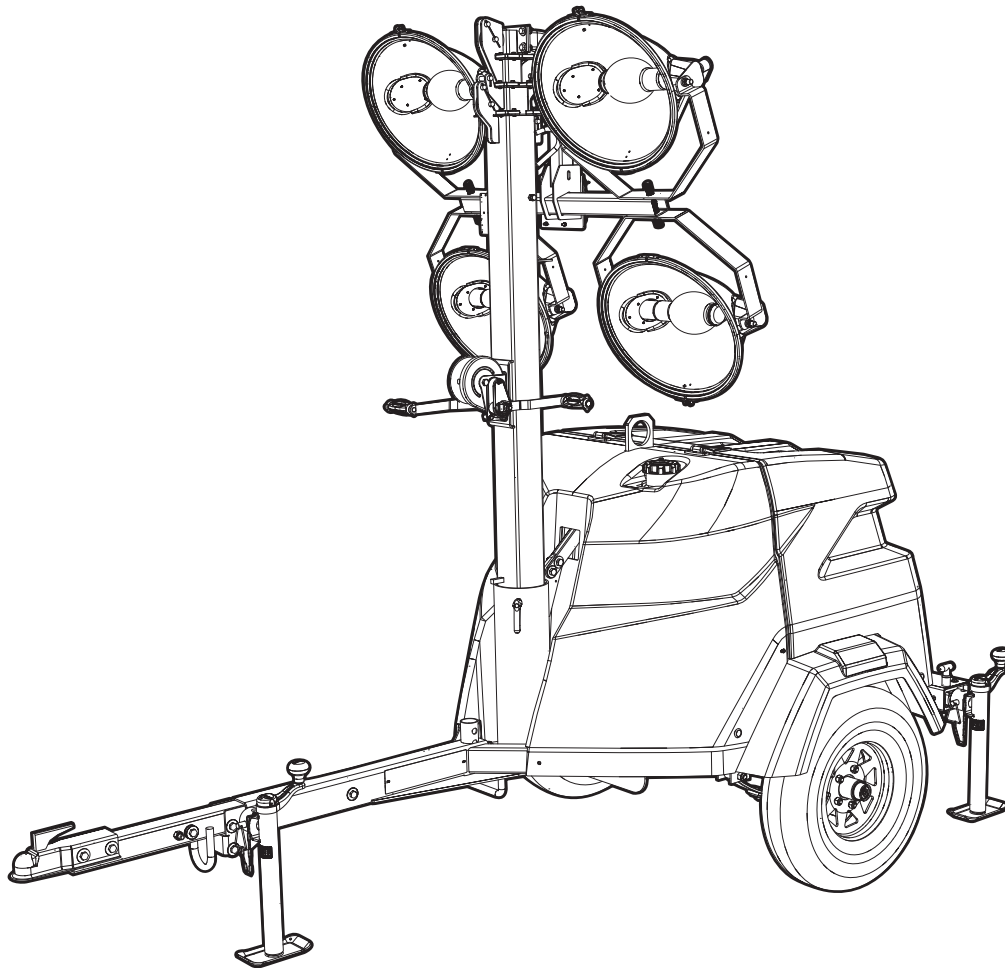

For technical assistance contact:
www.generacmobileproducts.com
Technical Support
1-800-926-9768

SAVE THIS MANUAL FOR FUTURE REFERENCE

Use this page to record important information about your light tower.

Unit Model Number	
Unit Serial Number	
Engine Model Number	
Engine Serial Number	
Generator Model Number	
Generator Serial Number	

Record the information found on your unit data label on this page. See [Unit Serial Number Locations](#).

Engine and generator serial numbers are located on separate data plates affixed to the engine and generator respectively. When contacting a Generac Mobile Products Authorized Service Dealer (GMP ASD) about parts and service, always provide the unit model and serial number.

Operation and Maintenance: Proper maintenance and care of the light tower ensures a minimum number of problems and keeps operating expenses at a minimum. It is the operator's responsibility to perform all safety checks, to verify that all maintenance for safe operation is performed promptly, and to have the equipment checked periodically by a GMP ASD. Normal maintenance, service, and replacement of parts are the responsibility of the owner/operator and, as such, are not considered defects in materials or workmanship within the terms of the warranty. Individual operating habits and usage may contribute to the need for additional maintenance or service.

⚠ WARNING

Operating, servicing and maintaining this equipment can expose you to chemicals including engine exhaust, carbon monoxide, phthalates, and lead, which are known to the State of California to cause cancer and birth defects or other reproductive harm. To minimize exposure, avoid breathing exhaust, do not idle the engine except as necessary, service your equipment in a well-ventilated area and wear gloves or wash your hands frequently when servicing your equipment.

For more information go to www.P65Warnings.ca.gov.

(000393)

⚠ WARNING

Breathing diesel engine exhaust exposes you to chemicals known to the State of California to cause cancer and birth defects or other reproductive harm.

- Always start and operate the engine in a well-ventilated area.
- If in an enclosed area, vent the exhaust to the outside.
- Do not modify or tamper with the exhaust system.
- Do not idle the engine except as necessary.

For more information go to www.P65Warnings.ca.gov/diesel.

(000394)

Table of Contents

Section 1: Introduction and Safety

Introduction	1
Read This Manual Thoroughly	1
Safety Rules	1
How to Obtain Service	1
General Hazards	2
Explosion and Fire Hazards	2
Trailer Hazards	2
Electrical Hazards	3
Battery Hazards	3
Fuel Hazards	4
Engine Safety	4
Operating Safety	4
Positioning the Unit	4
Starting the Unit	4
Raising and Lowering the Mast	5
Service Safety	5
Towing Safety	6
Hitch and Coupling	6
Running Lights	6
Wheels and Tires	6
Safe Towing Techniques	6
Reporting Trailer Safety Defects	6
Safety and Operating Decals	7

Section 2: General Information

Specifications	11
Unit Serial Number Locations	12
Trailer Tongue Storage and Tow Positions	13
Place Trailer Tongue in Tow Position	13
Place Trailer Tongue in Storage Position	14
Unit Dimensions	15
Component Locations	16
Control Panel	18
Control Panel Features and Functions	18
Power Zone–DLA (If Equipped)	19
Controller Features and Functions	19
Operator Screens	20
Dusk to Dawn Screen	21

Section 3: Operation

Light Tower Setup	25
Raising the Mast—Manual Winch	26
Raising the Mast—Electric Winch (If Equipped)	27
Raising the Mast—Power Zone-DLA (If Equipped)	28
Prestart Checklist	29
Starting the Unit (Key Switch Models)	29
Preparing for Start-Up (Power Zone–DLA)	30
Select AUTO or MANUAL Mode	30
Manually Starting the Unit	30
Light Operation (Key Switch Models)	31
Light Operation (Power Zone–DLA (If Equipped))	31
Engine Derating	31
Wet Stacking	32
Dusk to Dawn Sensor (Power Zone–DLA (If Equipped))	32
Customer Convenience Receptacles	32
Shutting Down the Unit	32
Shutting Down the Unit (Power Zone–DLA (If Equipped))	33
Automatic Shutdown	33
Lowering the Mast—Manual Winch	33
Lowering the Mast—Electric Winch (If Equipped)	33
Manually Lowering the Mast	34
Lowering the Mast—Power Zone-DLA (If Equipped)	34
Positive Air Shutdown (PAS) (If Equipped)	34
Test the PAS	35
Reset the PAS	35
Lower Radiator Hose Heater (If Equipped)	35
Tandem Tow (If Equipped)	35
Telemetry (If Equipped)	35
Spark Arrester (If Equipped)	35
Heated Fuel Filter (If Equipped)	36
Towing the Unit	36
Lifting the Unit	36
Tying the Unit Down	37

Section 4: Maintenance

Emissions Information	39
Daily Walk-Around Inspection	39
General Maintenance	39
Preparing for Service	39
Cleaning the Unit	39
Inspecting the Unit	39
Basic Maintenance Schedule	40
Resetting the Maintenance Alarms (If Equipped)	42
Manual Winch: Use, Operation, and Maintenance	42
Prior to Use	42
Operation	42
Maintenance	42
Electric Winch (If Equipped): Use, Operation, and Maintenance	42
Winch Mechanical Brake	43
Trailer Wheel Bearings	43
Jack Maintenance	43

Section 5: Troubleshooting

General Troubleshooting	45
Troubleshooting the Lights	46

Section 6: Wiring Diagrams

Mast Junction Box Wiring and Light Connections	47
AC Wiring Diagram	48
AC Wiring Diagram—MLT6SK and MLT6SM Power Zone (If Equipped)	49
DC Wiring Diagram—MLT6SM	50
DC Wiring Diagram—MLT6SM Power Zone (If Equipped)	51
DC Wiring Diagram—MLT6SK	52
DC Wiring Diagram—MLT6SK Power Zone (If Equipped)	53
DC Wiring Option—Heated Fuel Filter – MLT6SM ..	54
DC Wiring Option—Heated Fuel Filter – MLT6SK ..	55
DC Wiring—Electric Winch Option	56
Trailer Lights Wiring	57
Trailer Lights Wiring—Power Zone (If Equipped)	58

Section 7: Service Log

Section 1: Introduction and Safety

Introduction

Thank you for purchasing a Generac Mobile Products, LLC product. This unit has been designed to provide high-performance, efficient operation, and years of use when maintained properly.

The information in this manual is accurate based on products produced at the time of publication. The manufacturer reserves the right to make technical updates, corrections, and product revisions at any time without notice.

Read This Manual Thoroughly



⚠️ WARNING

Consult Manual. Read and understand manual completely before using product. Failure to completely understand manual and product could result in death or serious injury. (000100a)

If any section of the manual is not understood, contact your nearest Generac Mobile Products Authorized Service Dealer, or contact Generac Mobile Products, LLC at 1-800-926-9768, or Generac Mobile Products Technical Service at 1-800-926-9768 or www.generacmobileproducts.com with any questions or concerns.

The owner is responsible for proper maintenance and safe use of the equipment. Comply with regulations the Occupational Safety and Health Administration (OSHA) has established, or with equivalent standards. Also, verify that the unit is applied, used, and maintained in accordance with the manufacturer's instructions and recommendations. Do nothing that might alter safe application/usage and render the unit in noncompliance with the aforementioned codes, standards, laws, and regulations.

Save these instructions for future reference. This manual contains important instructions for the unit that should be followed during setup, operation and maintenance of the unit and battery. ALWAYS supply this manual to any individual that will use this machine.

Safety Rules

The manufacturer cannot anticipate every possible circumstance that might involve a hazard. The alerts in this manual, and on tags and decals affixed to the unit, are not all inclusive. If using a procedure, work method, or operating technique that the manufacturer does not specifically recommend, verify that it is safe for others and does not render the equipment unsafe.

Throughout this publication, and on tags and decals affixed to the unit, DANGER, WARNING, CAUTION, and NOTE blocks are used to alert personnel to special instructions about a particular operation that may be hazardous if

performed incorrectly or carelessly. Observe them carefully. Alert definitions are as follows:

⚠️ DANGER

Indicates a hazardous situation which, if not avoided, will result in death or serious injury.

(000001)

⚠️ WARNING

Indicates a hazardous situation which, if not avoided, could result in death or serious injury.

(000002)

⚠️ CAUTION

Indicates a hazardous situation which, if not avoided, could result in minor or moderate injury.

(000003)

NOTE: Notes contain additional information important to a procedure and will be found within the regular text of this manual.

These safety alerts cannot eliminate the hazards that they indicate. Common sense and strict compliance with the special instructions while performing the action or service are essential to preventing accidents.

How to Obtain Service

When the unit requires servicing or repairs, contact a Generac Mobile Products Authorized Service Dealer (GMP ASD) for assistance. Service technicians are factory-trained and are capable of handling all service needs. For assistance locating a dealer, visit www.generacmobileproducts.com/parts-service/find-service. When contacting a GMP ASD about parts and service, always supply the complete model number and serial number of the unit as given on its data decal located on the unit. Record the model number and serial numbers in the spaces provided on the inside front cover of this manual.

General Hazards



⚠ DANGER

Asphyxiation. Running engines produce carbon monoxide, a colorless, odorless, poisonous gas. Carbon monoxide, if not avoided, will result in death or serious injury. (000103)



⚠ WARNING

Hearing Loss. Hearing protection is recommended when using this machine. Failure to wear hearing protection could result in permanent hearing loss. (000107)



⚠ WARNING

Moving Parts. Keep clothing, hair, and appendages away from moving parts. Failure to do so could result in death or serious injury. (000111)



⚠ WARNING

Hot Surfaces. When operating machine, do not touch hot surfaces. Keep machine away from combustibles during use. Hot surfaces could result in severe burns or fire. (000108)

⚠ WARNING

Risk of injury. Do not operate or service this machine if not fully alert. Fatigue can impair the ability to service this equipment and could result in death or serious injury. (000215)



⚠ WARNING

Risk of burns. Allow engine to cool before draining oil or coolant. Failure to do so could result in death or serious injury. (000139)

Explosion and Fire Hazards



⚠ DANGER

Explosion and Fire. Fuel and vapors are extremely flammable and explosive. Add fuel in a well ventilated area. Keep fire and spark away. Failure to do so will result in death or serious injury. (000105)



⚠ WARNING

Risk of Fire. Unit must be positioned in a manner that prevents combustible material accumulation underneath. Failure to do so could result in death or serious injury. (000147)



⚠ WARNING

Risk of Fire. Hot surfaces could ignite combustibles, resulting in fire. Fire could result in death or serious injury. (000110)

Trailer Hazards

⚠ WARNING

Personal injury. Trailer must be securely coupled to the hitch with the chains correctly attached. Uncoupled or unchained towing could result in death or serious injury. (000233a)

⚠ WARNING

Personal injury. Do not operate unit during transport. Doing so could result in death, serious injury, or property damage. (000231a)

⚠ WARNING

Crushing hazard. Verify unit is properly secured and on level ground. An unsecured unit can suddenly roll or move, causing death or serious injury. (000234a)

⚠ WARNING

Property or Equipment Damage. Tighten wheel lug nuts after first 50 miles to factory specifications. Failure to do so could result in death, serious injury, property or equipment damage. (000235)

Electrical Hazards



⚠ DANGER

Electrocution. In the event of electrical accident, immediately shut power OFF. Use non-conductive implements to free victim from live conductor. Apply first aid and get medical help. Failure to do so will result in death or serious injury. (000145)



⚠ DANGER

Electrocution. Water contact with a power source, if not avoided, will result in death or serious injury.

(000104)



⚠ DANGER

Electrocution. Contact with bare wires, terminals, and connections while generator is running will result in death or serious injury.

(000144)



⚠ DANGER

Electrocution. Verify electrical system is properly grounded before applying power. Failure to do so will result in death or serious injury.

(000152)



⚠ DANGER

Electrocution. Do not wear jewelry while working on this equipment. Doing so will result in death or serious injury.

(000188)



⚠ DANGER

Electrocution. DO NOT use the unit if electrical cord is cut or worn through. Doing so will result in death or serious injury.

(000263a)

Battery Hazards



⚠ DANGER

Electrocution. Do not wear jewelry while working on this equipment. Doing so will result in death or serious injury.

(000188)



⚠ WARNING

Explosion. Batteries emit explosive gases while charging. Keep fire and spark away. Wear protective gear when working with batteries. Failure to do so could result in death or serious injury.

(000137a)



⚠ WARNING

Explosion. Do not dispose of batteries in a fire. Batteries are explosive. Electrolyte solution can cause burns and blindness. If electrolyte contacts skin or eyes, flush with water and seek immediate medical attention.

(000162)



⚠ WARNING

Risk of burn. Do not open or mutilate batteries. Batteries contain electrolyte solution which can cause burns and blindness. If electrolyte contacts skin or eyes, flush with water and seek immediate medical attention.

(000163a)

⚠ WARNING

Environmental Hazard. Always recycle batteries at an official recycling center in accordance with all local laws and regulations. Failure to do so could result in environmental damage, death or serious injury.

(000228)

Always recycle batteries in accordance with local laws and regulations. Contact your local solid waste collection site or recycling facility to obtain information on local recycling processes. For more information on battery recycling, visit the Battery Council International website at: <http://batteryCouncil.org>

Fuel Hazards



⚠ DANGER

Explosion and fire. Fuel and vapors are extremely flammable and explosive. No leakage of fuel is permitted. Keep fire and spark away. Failure to do so will result in death or serious injury. (000192)



⚠ DANGER

Risk of fire. Allow fuel spills to completely dry before starting engine. Failure to do so will result in death or serious injury. (000174)

- **DO NOT** fill fuel tank near an open flame, while smoking, or while engine is running. **DO NOT** fill tank in an enclosed area with poor ventilation.
- **DO NOT** operate with the fuel tank cap loose or missing.

Engine Safety

Internal combustion engines present special hazards during operation and fueling. Failure to follow the safety guidelines described below could result in severe injury or death. Read and follow all safety alerts described in the engine operator's manual. A copy of this manual was supplied with the unit when it was shipped from the factory.

- **DO NOT** run engine indoors or in an area with poor ventilation. Make sure engine exhaust cannot seep into closed rooms or ventilation equipment.
- **DO NOT** clean air filter with gasoline or other types of low flash point solvents.
- **DO NOT** operate the unit without a functional exhaust system.
- Shut the engine down if any of the following conditions exist during operation:
 - Noticeable change in engine speed.
 - Loss of electrical output.
 - Equipment connected to the unit overheats.
 - Sparking occurs.
 - Engine misfires or there is excessive engine/generator vibration.
 - Protective covers are loose or missing.
 - Ambient air temperature is above 120 °F (49 °C).

Operating Safety

Positioning the Unit



⚠ DANGER

High Voltage. Verify area above unit is clear of overhead wires and obstructions. Contact with high-voltage power lines will result in death or serious injury. (000260a)



⚠ WARNING

Burn hazard. Never operate lights with a damaged or missing lens cover. Lamps are hot and pressurized while in use. Unprotected lamps can shatter, causing severe injury. (000277)

- The area immediately surrounding the unit should be dry, clean, and free of debris.
- Position and operate the unit on a firm, level surface.
- If the unit is equipped with a frame grounding stud, follow any local, state, and National Electrical Code (NEC) guidelines when connecting.

Starting the Unit



⚠ DANGER

Electrocution. **DO NOT** use the unit if electrical cord is cut or worn through. Doing so will result in death or serious injury. (000263a)

⚠ WARNING

Equipment damage. Do not attempt to start or operate a unit in need of repair or scheduled maintenance. Doing so could result in serious injury, death, or equipment failure or damage. (000291)

Raising and Lowering the Mast



⚠️ WARNING

Electrocution. Do not set up or operate this unit if severe weather is expected. Lightning strikes can kill or cause severe injury even if you are not touching the unit. (000296)



⚠️ WARNING

> 60 mph Do not set up the unit if high winds are expected. High winds can cause the unit to tip or fall, causing severe injury or machine damage. (000297)

⚠️ WARNING

Personal injury or equipment damage. Do not raise or lower the mast while the unit is operating. Doing so can break the lenses and cause the lamps to shatter. (000279)

⚠️ WARNING

Personal Injury. Stop immediately if the mast hangs up or the winch cable develops slack. Excess slack could cause the mast to collapse, resulting in personal injury or equipment damage. (000265)

⚠️ WARNING

Tipping hazard. Extend the outriggers and level the unit before raising the mast. Keep the outriggers extended while the mast is up. Failure to do so could cause the unit to tip and fall and could result in death or serious injury. (000266)

- Keep area around the unit clear of people while raising and lowering the mast.
- **ALWAYS** lower the mast when not in use.
- The tower extends up to 23 ft (7 m). Verify area above trailer is open and clear of overhead wires and obstructions.
- If for any reason any part of the mast hangs up or winch cable develops slack while raising or lowering tower, stop immediately and contact a GMP ASD.
- **NEVER** remove safety pin or pull mast locking pin while tower is up.

Service Safety

⚠️ WARNING

Accidental start-up. Disconnect negative battery terminal before servicing to prevent accidental engine rotation. Failure to do so could result in death or serious injury. (000148a)

This unit uses high voltage circuits capable of causing serious injury or death. Only a qualified and licensed electrician should troubleshoot or repair problems occurring in this equipment.

- Before servicing the unit, verify the control power switch and circuit breakers are OFF (O), and the negative (-) terminal on the battery is disconnected. **DO NOT** perform even routine service (oil/filter changes, cleaning, etc.) unless all electrical components are shut down.
- **ALWAYS** use extreme caution when servicing this unit in damp conditions. Do not service the unit if skin or clothing is wet. Do not allow water to collect around the base of the unit.
- **DO NOT** wash the unit with high pressure hoses, power washers, or steam cleaners. Water may collect in the unit, causing damage to electrical parts.
- Replace all missing and hard to read decals. Decals provide important operating instructions and warn of dangers and hazards.
- Wear heavy leather gloves when handling winch cables. Never let cables slip through bare hands.
- Only use mild soap and water to clean the lens covers. Other chemicals may damage the lens covers.

Towing Safety

Towing a trailer requires care. Both the trailer and vehicle must be in good condition and securely fastened to each other to reduce the possibility of an accident. Some states require that large trailers be registered and licensed. Contact your local Department of Transportation office to check on license requirements for your particular unit.

Hitch and Coupling

- Verify the hitch and coupling on the towing vehicle are rated equal to, or greater than, the trailer's gross vehicle weight rating (GVWR).
- Verify the trailer hitch and the coupling are compatible. Verify the coupling is securely fastened to the vehicle.
- **DO NOT** tow trailer using defective parts. Inspect the hitch and coupling for wear or damage.
- Connect safety chains in a crossing pattern under the tongue.
- Before towing the trailer, verify that the weight of the trailer is equal across all tires. On trailers with adjustable height hitches, adjust the angle of the trailer tongue to keep the trailer as level as possible.

Running Lights

Verify directional and brake lights on the trailer are connected and working properly.

Wheels and Tires

- Inspect trailer tires for wear and proper inflation.
- Verify wheel lug nuts are present and tightened to the specified torque.

Safe Towing Techniques

- Practice turning, stopping, and backing up in an area away from heavy traffic prior to transporting the unit.
- Maximum recommended speed for highway towing is 45 mph (72 km/h). Recommended off-road towing speed is 10 mph (16 km/h) or less, depending on terrain.
- When towing, maintain extra space between vehicles and avoid soft shoulders, curbs, and sudden lane changes.

Reporting Trailer Safety Defects

If you believe your trailer has a defect which could cause a crash or could cause injury or death, you should immediately inform the National Highway Traffic Safety Administration (NHTSA) in addition to notifying Generac Mobile Products, LLC.

If NHTSA receives similar complaints, it may open an investigation; and if it finds that a safety defect exists in a group of vehicles, it may order a recall and remedy campaign. However, NHTSA cannot become involved in an individual problem between you, your dealer, or Generac Mobile Products, LLC.

To contact NHTSA, you may either call the Auto Safety Hotline toll-free at 1-888-327-4236 (TTY:1-800-424-9153), go to <http://www.safercar.gov>; or write to:

Administrator
NHTSA
1200 New Jersey Avenue S.E.
Washington, DC 20590

You can also obtain other information about motor vehicle safety from <http://www.safercar.gov>.

Safety and Operating Decals

See [Figure 1-1](#) through [Figure 1-3](#). This unit features numerous safety and operating decals. These decals provide important operating instructions and warn of dangers and hazards. The following diagrams illustrate decal locations and descriptions.

Replace any missing or hard-to-read decals and use care when washing or cleaning the unit. Decal part numbers can be found in the parts manual at www.generacmobileproducts.com.

ID	Description	ID	Description
1	Setup and Take-Down Instructions (Electric)	15	Control Panel Label (not shown)
2	Setup and Take-Down Instructions (Manual)	16	Neutral Bonded to Frame
3	Danger—Overhead Power Lines	17	Not A Step
4	Warning—Electrical Storms and High Wind	18	Warning—High Temperature: Do Not Remove Guard
5	Owner's Manual Location	19	Mast Junction Box Wiring (inside)
6	Electric Shock Hazard	20	Warning—Do Not Retract Outriggers With Tower Up
7	Warning—Hot Surface	21	Stowed Position
8	Warning—Pressurized Liquid	22	Lifting Point
9	Warning—Entanglement Hazard	23	Forklift and Tie-Down Point
10	Warning—Cutting Hazard	24	Engine Operation
11	Disconnect Battery Before Servicing	25	Ultra Low Sulfur Diesel Fuel Only
12	Danger—Carbon Monoxide	26	Danger—Fuel and Fueling Hazards
13	Electrical Ground Connection	27	Tie-Down Point
14	Danger—Ultraviolet Radiation / Winch Operation	28	Towing Instructions

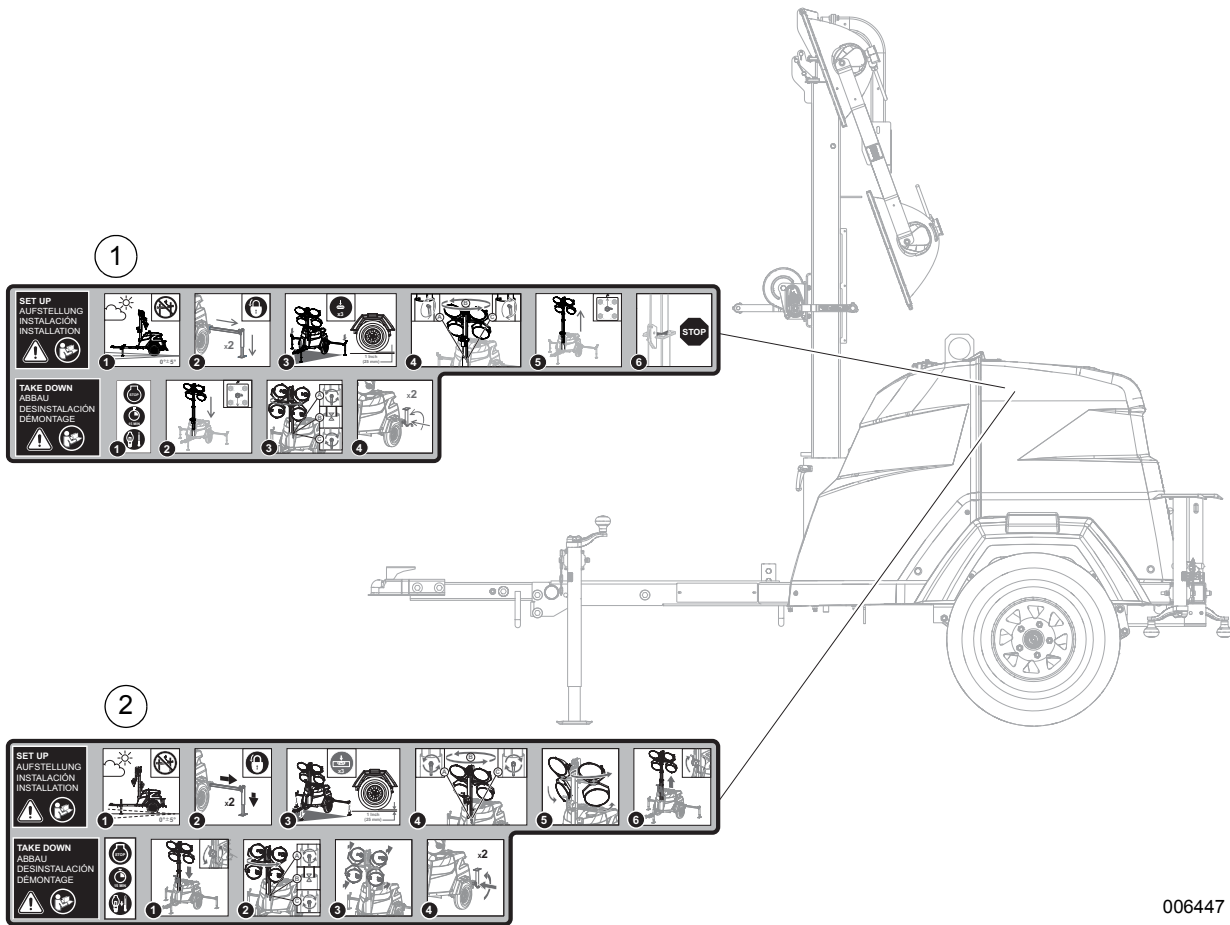

006447

Figure 1-1. Decal Locations (1 of 3)

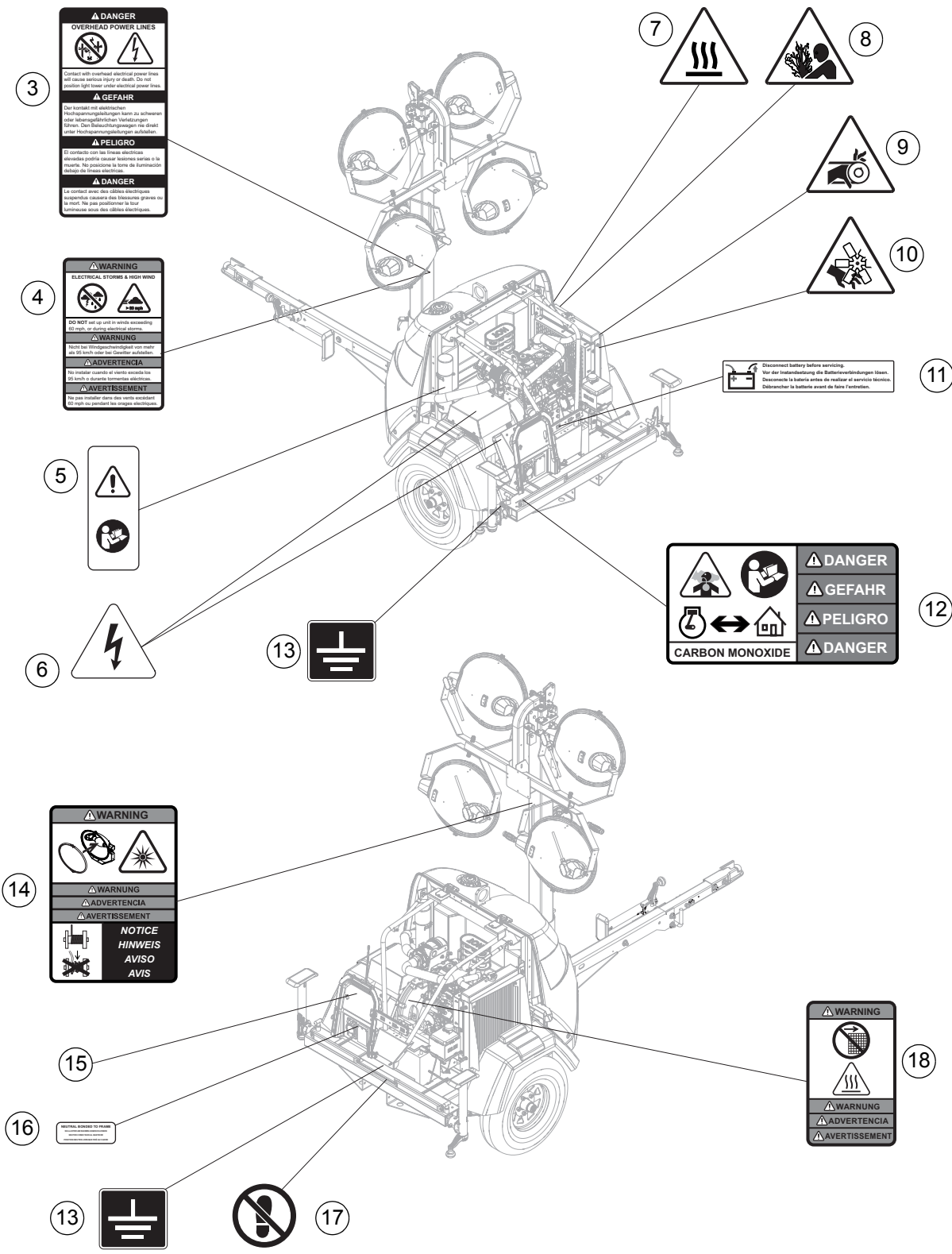

Figure 1-2. Decal Locations (2 of 3)

006448

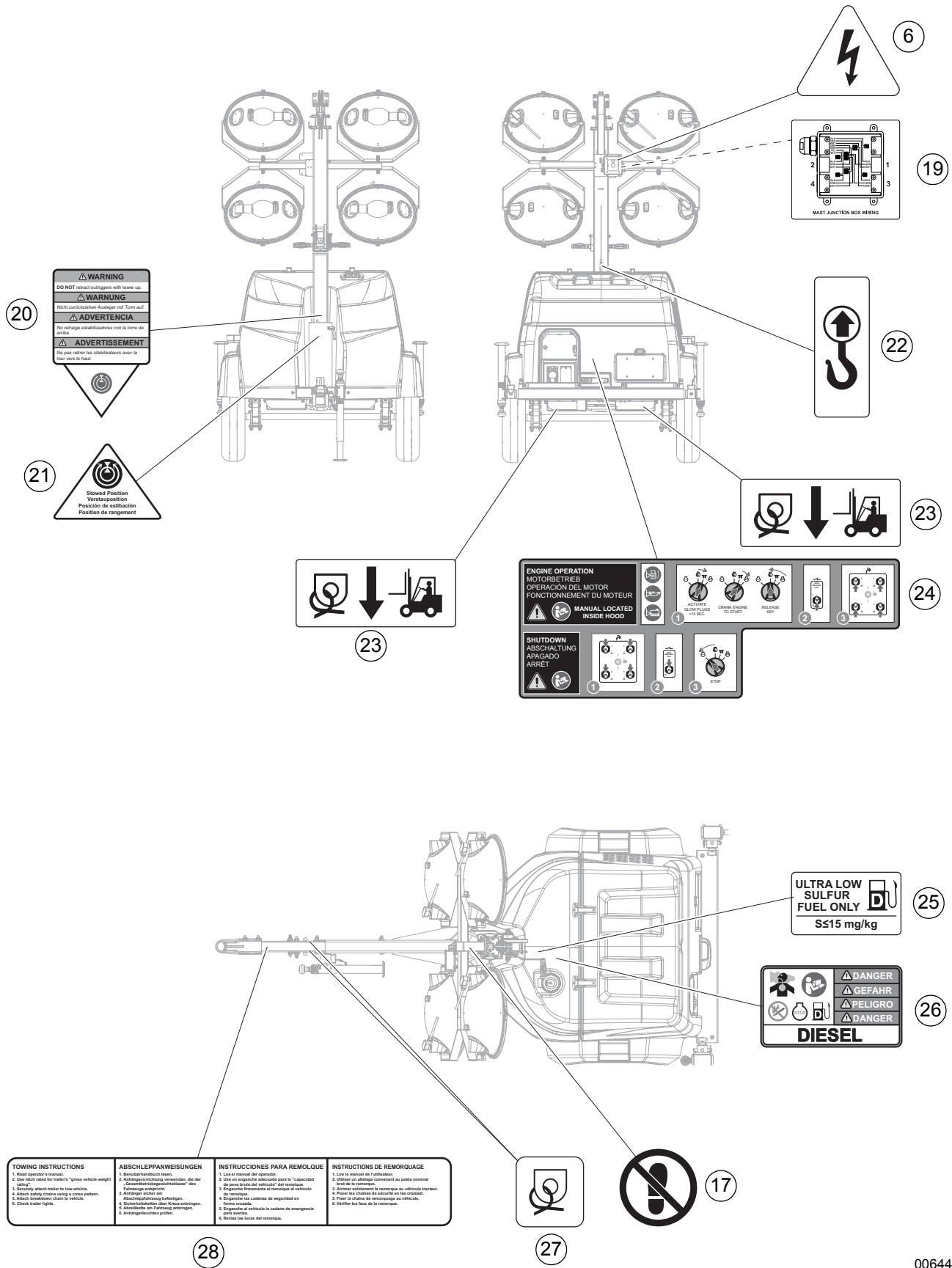

Figure 1-3. Decal Locations (3 of 3)

006449a

Section 2: General Information

Specifications

DESCRIPTION	UNITS	MLT6SM	MLT6SK
Engine			
Manufacturer		Mitsubishi®	Kubota®
Model		L3E-W461ML	D1005-E3BG1-MGM-1
EPA Tier	—	Tier 4 Final	Tier 4 Final
Fuel Consumption—100% Prime	gph (Lph)	0.59 (2.24)	0.58 (2.18)
Battery Type—Group Number	—	24	24
Battery Voltage	quantity per unit	12V (1)	12V (1)
Battery Rating	cold-cranking amps (CCA)	440	440
Generator			
Make	—	Marathon®	
Model	—	201CSA5423	
Output - Standby	kW (kVA)	6.0 (6.0)	
Output Voltage	volts	120V/240V, single phase	
Output Amperes 120V (240V)	amperes	15 (25)	
Frequency	Hertz	60	
Weights			
Dry Weight	lbs (kg)	1,290 (585)	1,330 (603)
Operating Weight	lbs (kg)	1,560 (708)	1,600 (726)
Capacities			
Fuel Tank Volume	gal (L)	40.8 (154.5)	40.8 (154.5)
Usable Fuel Volume	gal (L)	39.9 (151)	39.9 (151)
Coolant (including engine)	qt (L)	4.5 (4.3)	4.8 (4.5)
Oil (including filter)	qt (L)	5.0 (4.7)	5.4 (5.1)
Maximum Run Time at Full Load	hours	90	84
AC Distribution			
Circuit Breaker Size	amperes	30	
Trailer			
Hitch—Standard	—	2 in (51 cm) ball	
Maximum Tire Pressure	psi (kPA)	50 (345)	
<i>Specifications are subject to change without notice.</i>			

Unit Serial Number Locations

Refer to the illustration to locate the unit ID tag and Vehicle Identification Number (VIN) tag on the unit. Important information, such as the unit serial number, model number, VIN, and tire loading information are found on these tags. Record the information from these tags so it is available if the tags are lost or damaged. When ordering parts or requesting assistance, you may be asked to provide this information.

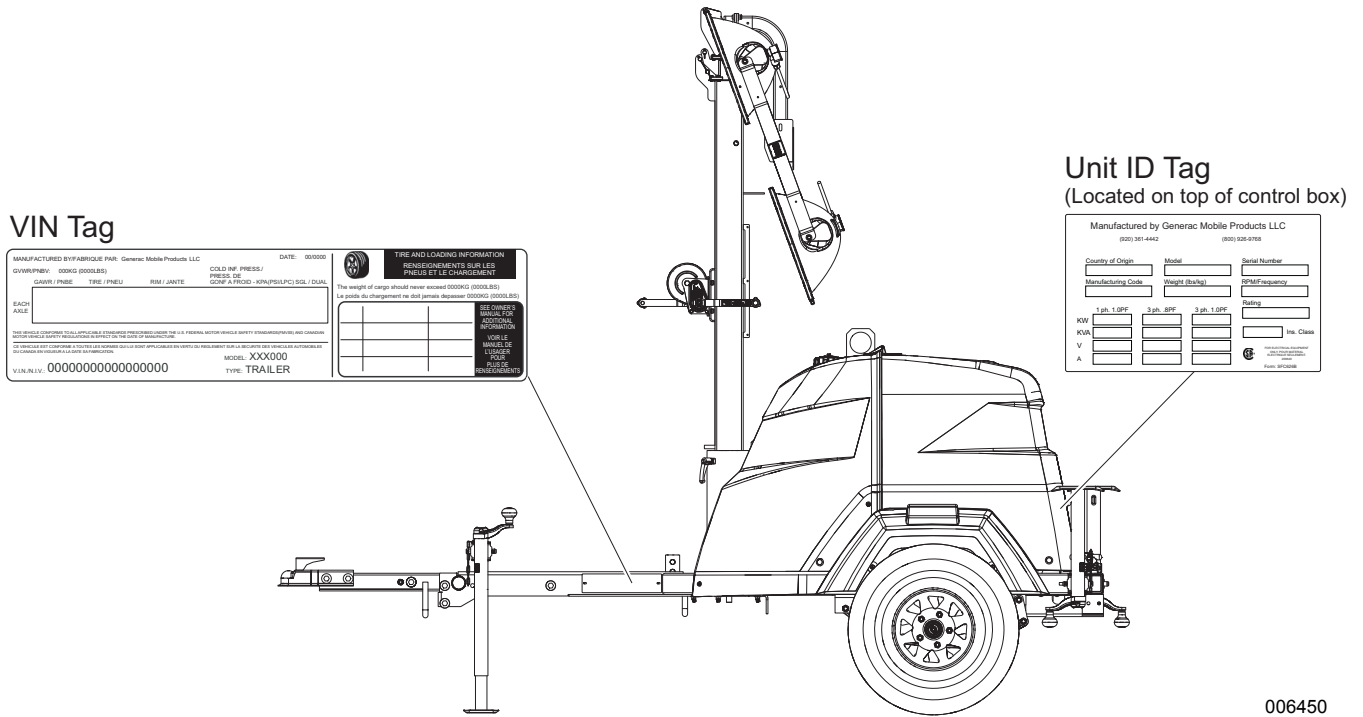

Figure 2-1. Serial Number Locations

006450

Trailer Tongue Storage and Tow Positions

The trailer tongue is designed to fold upright for shipping and storage.

IMPORTANT NOTE: Do not attempt to tow the unit with trailer tongue in the storage position.

Place Trailer Tongue in Tow Position

1. Verify unit is on a level surface and wheels are blocked.

NOTE: See [Figure 2-2](#). Unit ships from factory with jack in the storage location (A).

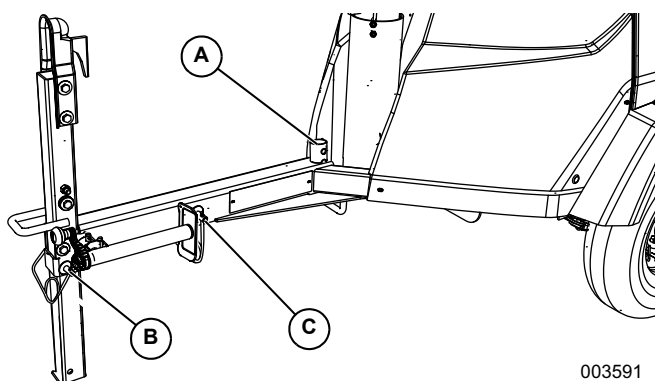

Figure 2-2. Jack and Pin Locations

2. Remove clevis securing jack parallel to ground.
3. Remove jack from tongue weldment. Hold jack vertically and extend until weldment on jack is aligned with tongue weldment.
4. See [Figure 2-3](#). Install jack and secure with clevis (D).

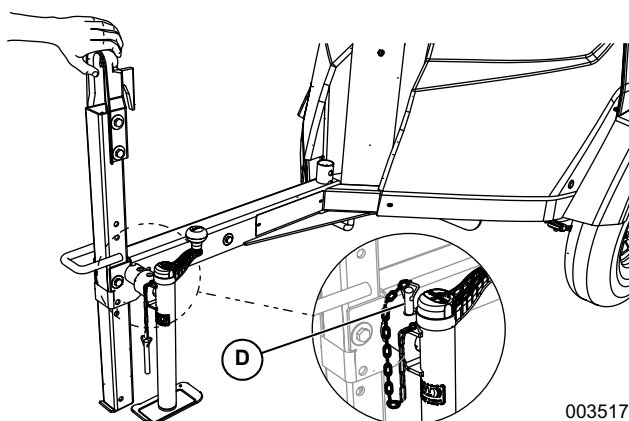

Figure 2-3. Jack Installed

5. See [Figure 2-2](#). Remove pins (B) and (C).



CAUTION

Pinching and crushing hazard. To avoid possible injury, keep fingers away from pivot point when folding or unfolding trailer tongue.

(000313)

6. See [Figure 2-4](#). Using both hands, slowly lower trailer tongue into tow position.

NOTE: Varying levels of effort may be required depending on terrain.

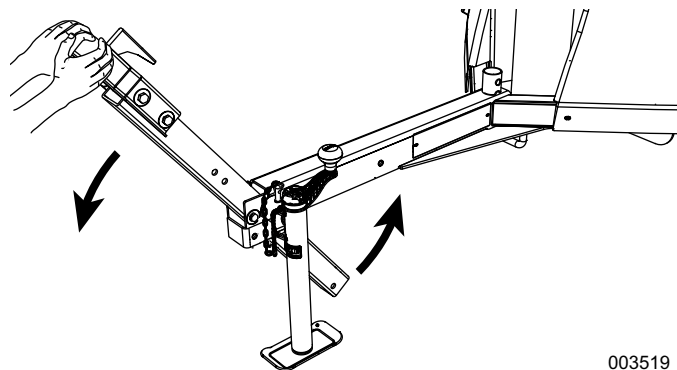

003519

Figure 2-4. Lower Trailer Tongue into Tow Position

7. See [Figure 2-5](#). Install pins as shown to secure trailer tongue in tow position.

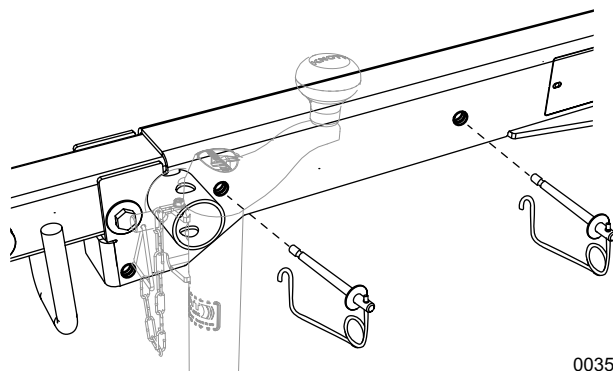

003592

Figure 2-5. Install and Secure Pins

Place Trailer Tongue in Storage Position

1. Verify unit is on a level surface and wheels are blocked.
2. See **Figure 2-6**. Extend jack (A) enough to allow minimum effort to pivot trailer tongue into storage position.

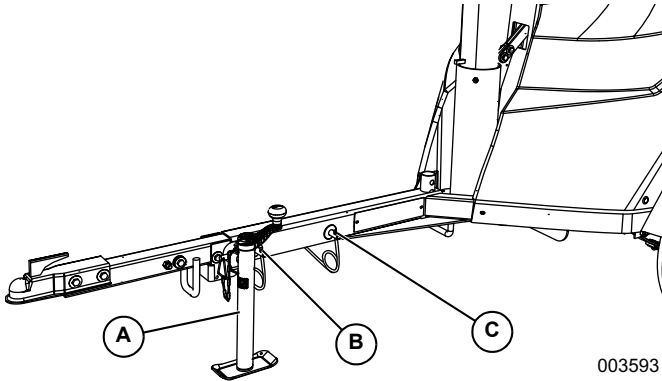

Figure 2-6. Extend Jack and Remove Pins

3. Remove pins (B) and (C) from trailer tongue.



CAUTION

Pinching and crushing hazard. To avoid possible injury, keep fingers away from pivot point when folding or unfolding trailer tongue.

(000313)

4. See **Figure 2-7**. Pivot trailer tongue into storage position.

NOTE: Varying levels of effort may be required depending on terrain.

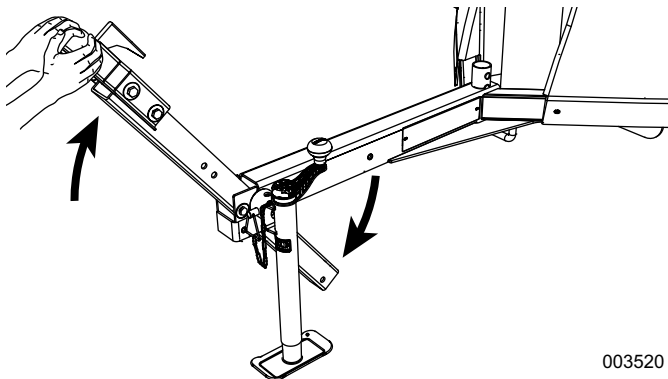

Figure 2-7. Pivot Trailer Tongue Into Storage Position

5. See **Figure 2-8**. Install pins (B) and (C) at locations shown to secure trailer tongue in storage position.

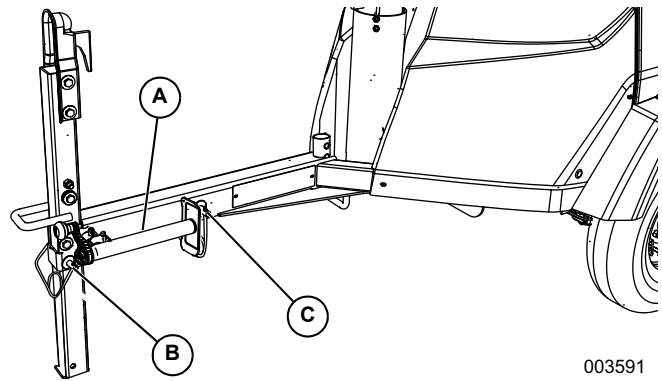
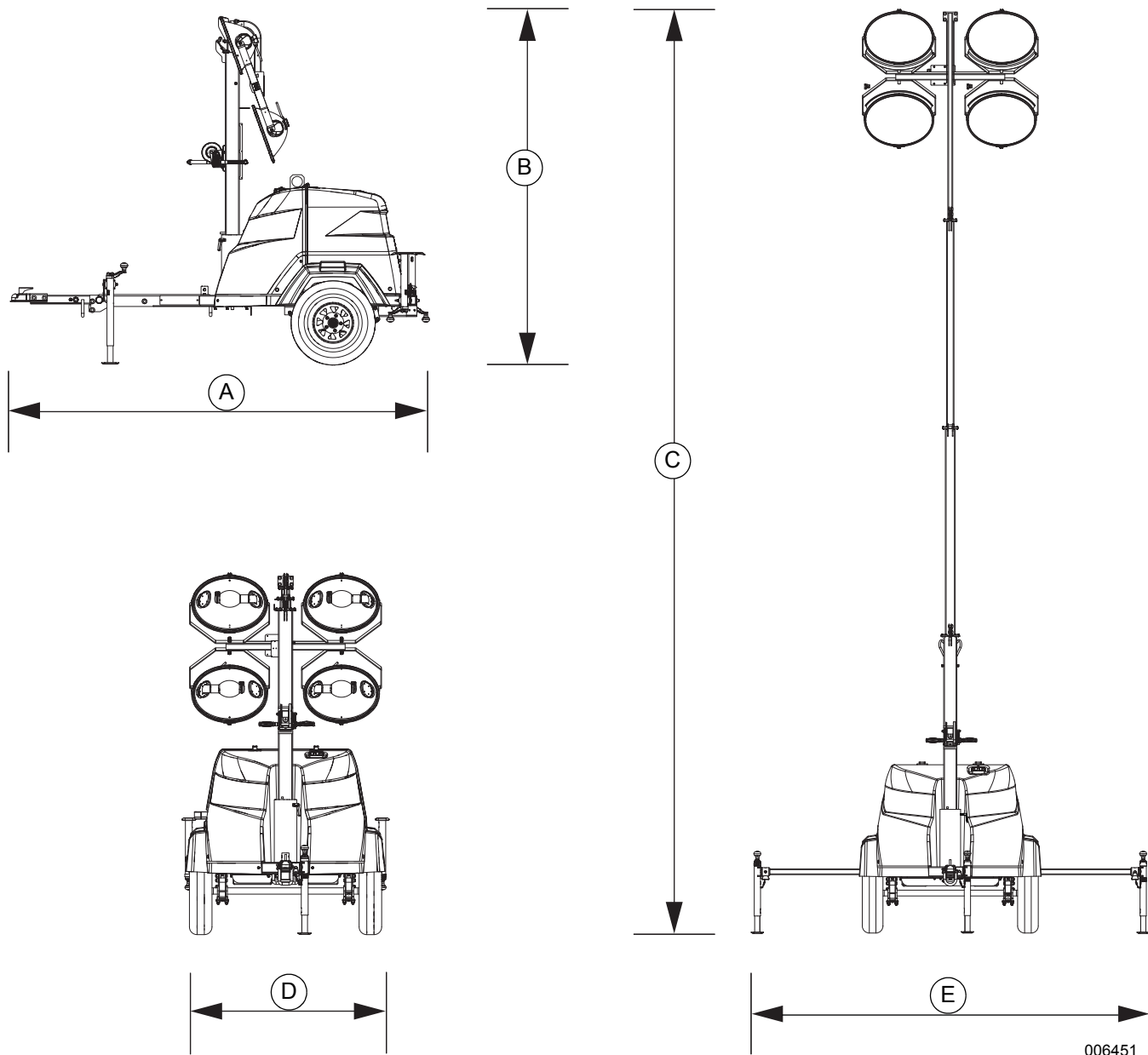

Figure 2-8. Install Pins and Rotate Jack

6. Remove clevis and remove jack (A) from tongue weldment.
7. Completely retract jack.
8. Rotate jack 90° counterclockwise, place jack on tongue weldment, and install clevis to secure jack parallel to ground.

Unit Dimensions



006451

Figure 2-9. Unit Dimensions

	A	B	C	D	E
MLT6SM MLT6SK	118 in (3 m)	101 in (2.6 m)	23 ft (7 m)	57 in (1.5 m)	120.5 in (3.1 m)

Specifications are subject to change without notice.

Component Locations

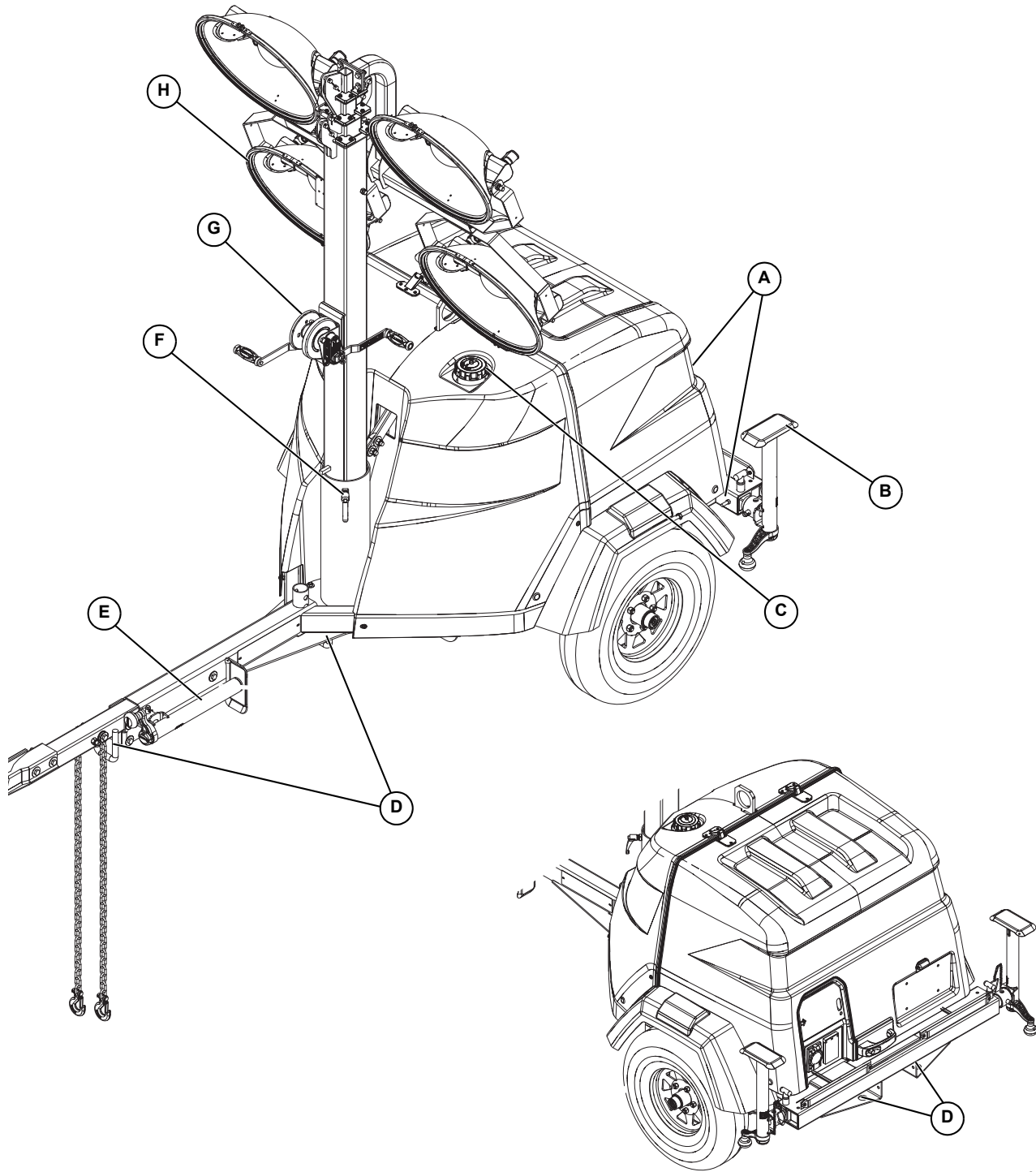

006452

Figure 2-10. Component Locations—Front and Left Side

- | | |
|---|---|
| <p>A Grounding studs:
Interior: On enclosure floor behind controller
Exterior: On bumper</p> <p>B Outriggers and Jacks (2)</p> <p>C Fuel fill</p> <p>D Tie-down locations (4)</p> | <p>E Tongue jack</p> <p>F Mast rotation knob</p> <p>G Winch</p> <p>H Lights (4)</p> |
|---|---|

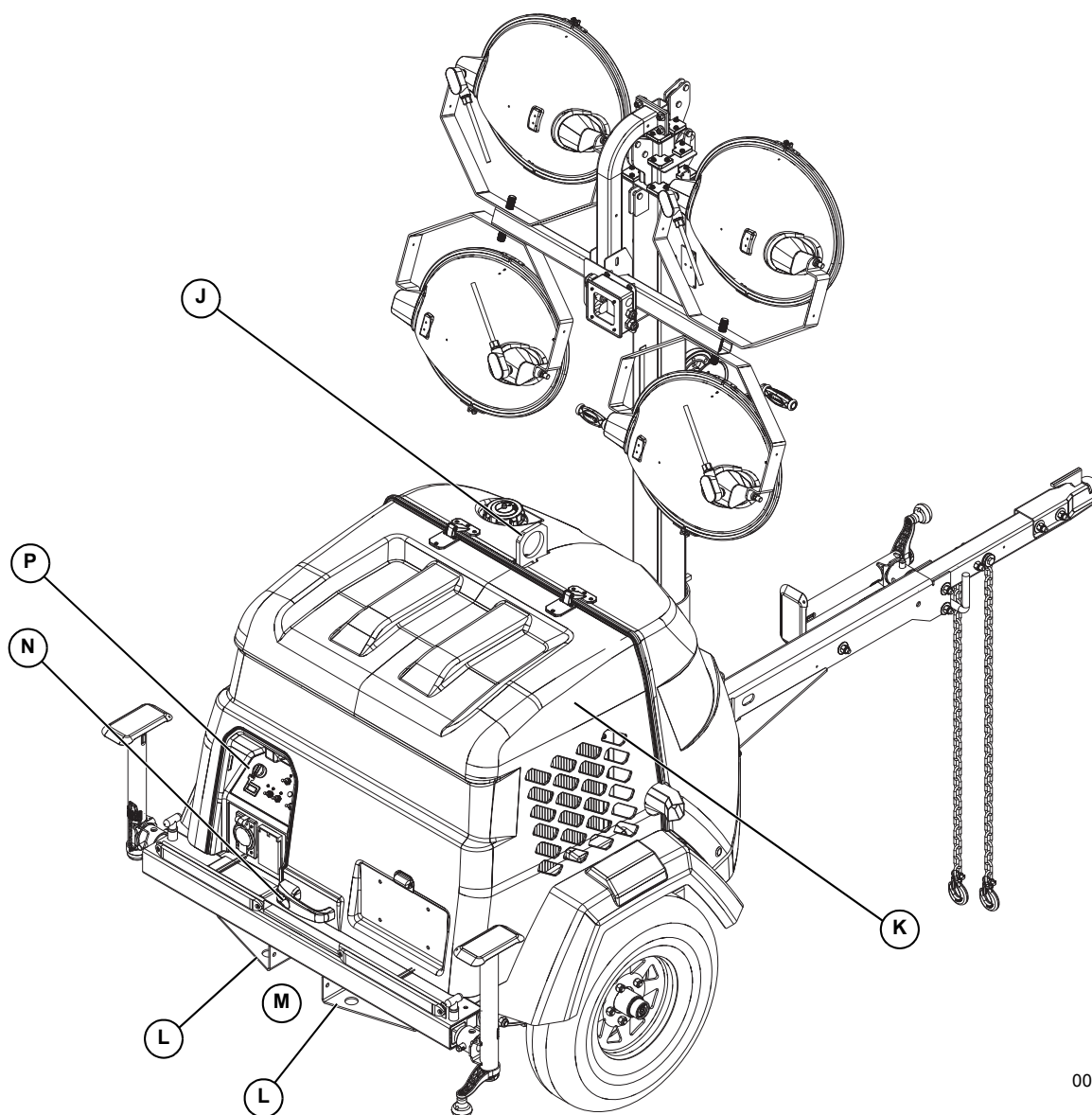

006453

Figure 2-11. Component Locations—Rear and Right Side

- | | | | |
|---|-----------------------------|---|---|
| J | Central lift point | M | Tandem tow mount (optional—not shown) |
| K | Engine/radiator access hood | N | Hood latch |
| L | Forklift pocket | P | Key start controller or Power Zone™-DLA controller (optional—not shown) |

Control Panel

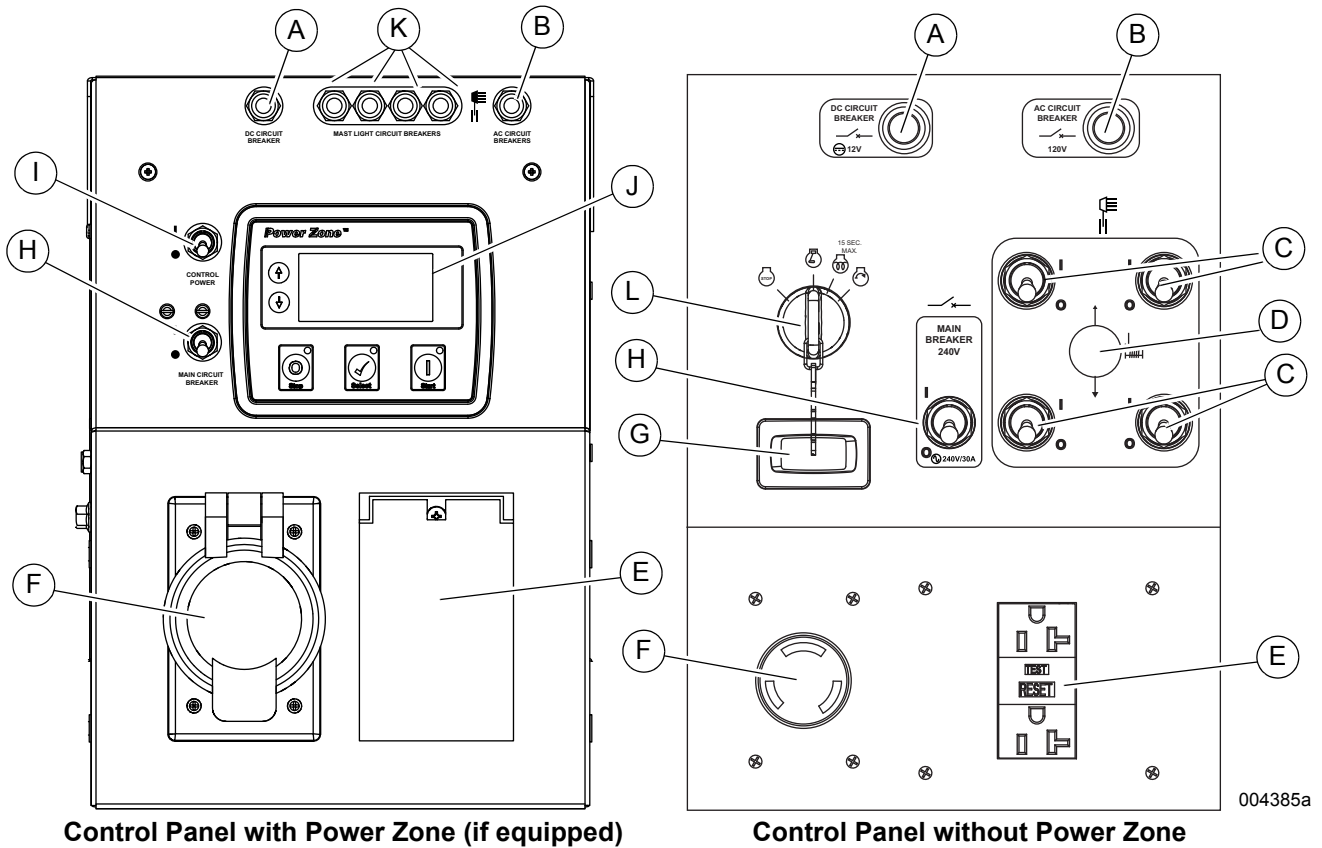

Figure 2-12. Control Panel Features

Control Panel Features and Functions

(A) DC circuit breaker

Resets the DC electrical circuit that powers the control panel and engine components.

(B) AC circuit breaker

Resets the AC electrical circuit that powers the control panel.

(C) Mast light switches/circuit breakers (4)

Power switches with internal breakers dedicated to individual lights.

(D) Mast switch (if equipped)

Raises and lowers the mast on units equipped with an electric winch.

(E) 120V/20A GFCI receptacle

Customer convenience receptacle for use in connecting auxiliary equipment such as fans, pumps, or drills. Includes a ground fault circuit interrupter (GFCI) test and reset button.

(F) 240VAC/30A twist-lock receptacle

Customer convenience receptacle for use in connecting auxiliary equipment such as fans, pumps, or drills.

(G) Engine hour meter

Displays number of hours the engine has run.

(H) Main circuit breaker

240V/30A breaker which disconnects power from the lights and control panel.

(I) Control power switch

Turns the controller ON and OFF.

(J) Power Zone controller

Monitors the unit and indicates operational status and fault conditions.

(K) Mast light circuit breakers (4)

Circuit breakers with internal breakers dedicated to individual lights.

(L) 4-Position key switch

Operates the engine.

Power Zone–DLA (If Equipped)

The Power Zone–DLA is an AUTO start controller that monitors the unit and indicates operational status and fault conditions. The controller can be programmed to automatically start or stop based on time schedule, fault condition, or load demand.

The controller constantly monitors vital generator and engine functions for a number of preprogrammed alarm and fault conditions. When a fault condition occurs, the

engine shuts down automatically and the LCD window shows the fault that caused the shutdown. To resume operation, the fault condition must be corrected.

This controller records a history of unit performance, which may be viewed at any time and will not be lost when the controller is powered down.

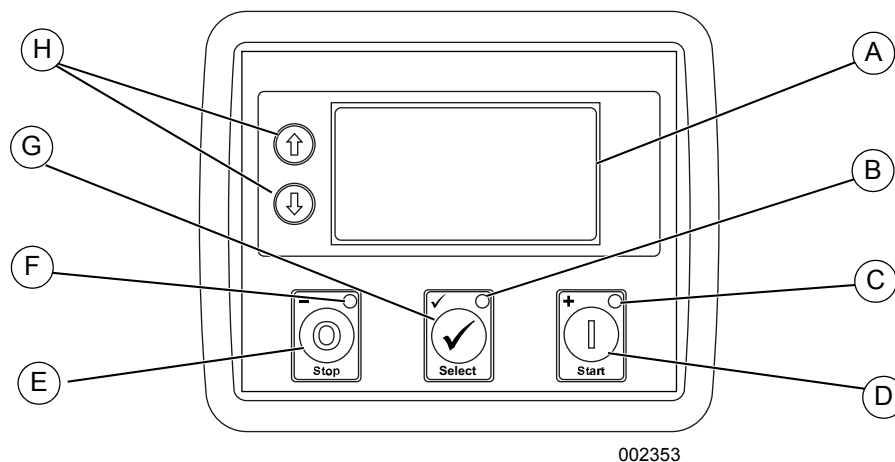

Figure 2-13. Power Zone–DLA Layout

Controller Features and Functions

(A) The Liquid Crystal Display (LCD) Window

Displays the various operating screens. By viewing these screens, the operator can monitor both the engine and generator status while the unit is running.

(B) Select LED

Illuminates when the unit is running in AUTO mode.

(C) Start LED

Illuminates when the unit is running in MANUAL mode.

(D) Start Button

Starts the engine if there are no shutdown errors and the engine is in “ready to start” status.

(E) Stop Button

Shuts down the unit and puts the controller into STOP mode, whether in MANUAL mode or AUTO mode.

NOTE: To prevent damage to the generator and connected equipment, remove all loads from the generator by opening all circuit breakers (turn OFF [O]) before pressing the STOP button.

(F) Stop LED

Illuminates when the unit is in STOP mode and flashes when an Electrical Trip and Shutdown Fault has occurred.

(G) Select Button

Confirms entries chosen in the various edit menus and screens.

(H) Menu Navigation

Up/down arrows (↑, ↓) used to navigate through the various operator screens. They are also used to raise and lower the mast on units equipped with an electric winch.

Operator Screens

See [Figure 2-14](#). The operator screens display the most relevant and critical information needed to properly configure and use the unit. From these six screens, the operator can access information necessary to operate the unit under normal conditions.

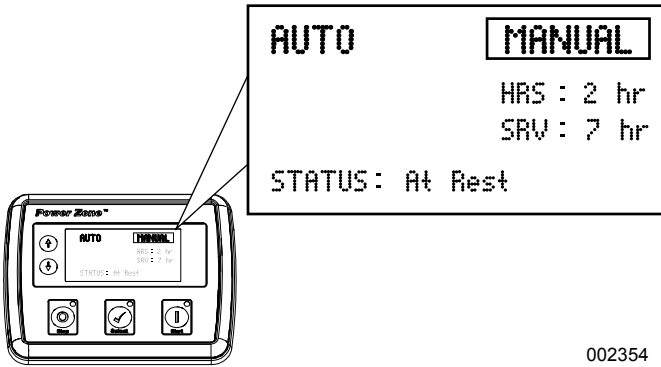

Figure 2-14. Operator Screens Location

Home Screen

See [Figure 2-15](#). The Home screen is the default screen of the controller and displays after the controller is powered up and the unit management software is loaded. It displays the controller mode, total operating hours, hours left until the next service interval, engine operating status, and engine rpm. If the unit is in AUTO mode, the Home screen may also display whether the scheduler or “dusk to dawn” is enabled.

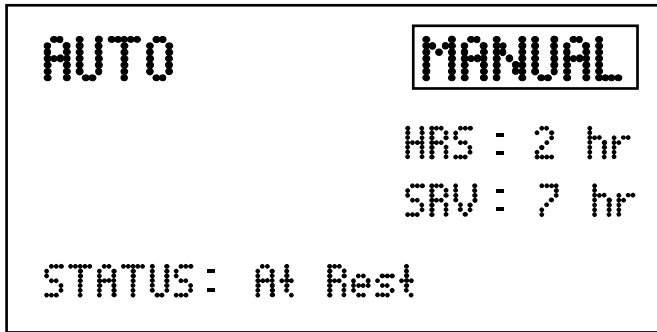

Figure 2-15. Home Screen

Mast Operation Screen

See [Figure 2-16](#). Mast Operation Screen allows the operator to raise or lower the mast.

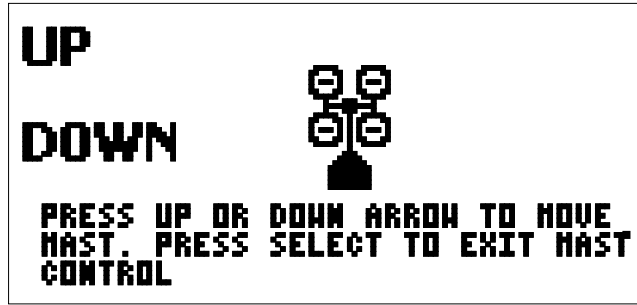

Figure 2-16. Mast Operation Screen

Battery Voltage Screen

See [Figure 2-17](#). Displays the engine battery voltage. A normal reading is 12-14V on 12 volt systems (with the engine running).

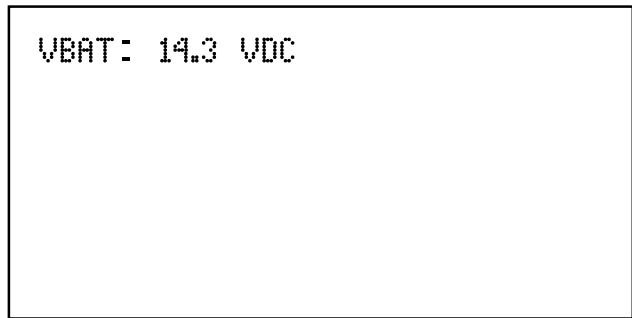
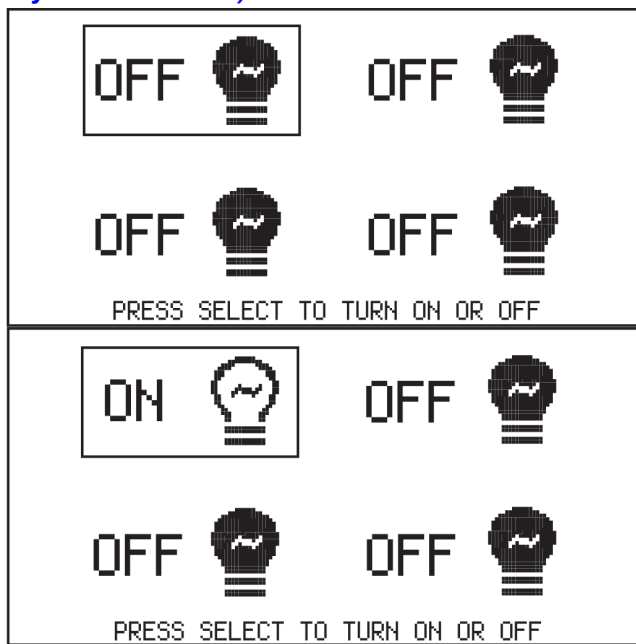

Figure 2-17. Battery Voltage Screen

Lights Screen

See [Figure 2-18](#). The Lights screen allows the operator to turn the lights on and off. Refer to [Light Operation \(Key Switch Models\)](#) for more information.



002327

Figure 2-18. Lights Screen

Line Amperage Screen

See [Figure 2-19](#). The Line Amperage screen displays the AC output amperage produced by the generator in amps (A). The load balance for each line (L1 and L3) is displayed in both numerical and graphical form. It is important to maintain a balanced load distribution between lines for optimum generator performance.

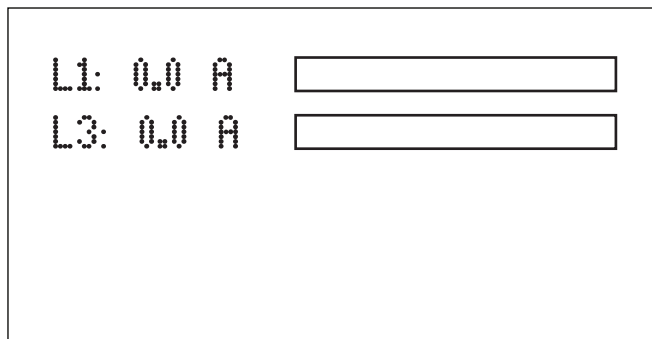

002980

Figure 2-19. Line Amperage Screen

Generator Screen

See [Figure 2-20](#). The Generator screen displays the average line voltage, frequency (in Hertz), and power factor for the generator while in operation.

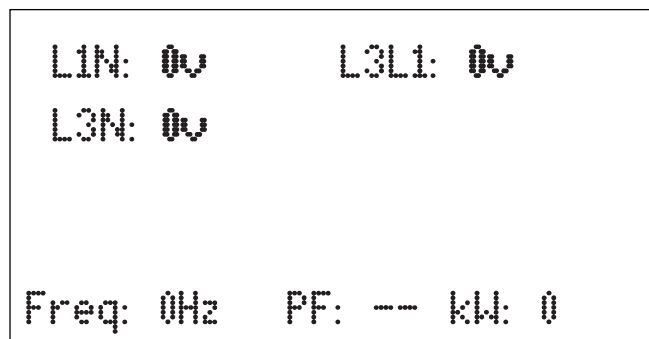

002981

Figure 2-20. Generator Screen

Dusk to Dawn Screen

NOTE: This feature will only work in AUTO mode.

See [Figure 2-21](#). The Dusk to Dawn screen enables or disables the “dusk to dawn” function. This function uses a photo sensor to detect the surrounding light level, automatically starting the engine and turning the lights on at dusk. The engine will run and the lights will remain illuminated until dawn.

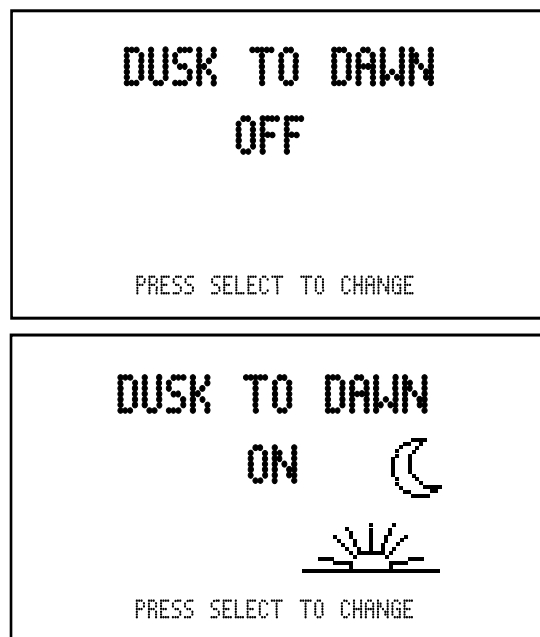

002328

Figure 2-21. Dusk to Dawn Screen

Scheduler Screen

NOTE: This feature will only work in AUTO mode.

See [Figure 2-22](#). The Scheduler screen allows the operator to program specific times for the lights to turn on and off. Once programmed, the Scheduler will start the engine and illuminate the lights until the designated shutdown time.

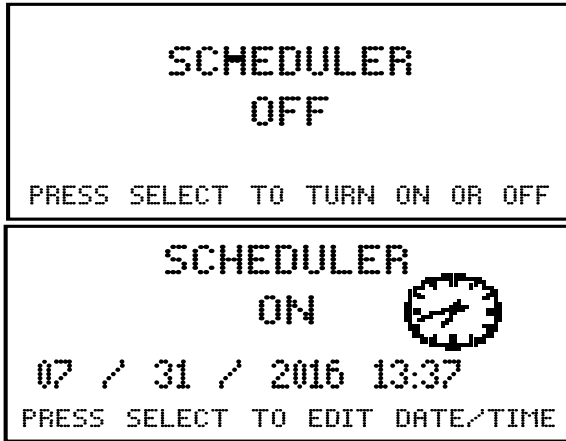

002329

Figure 2-22. Scheduler Screen

Maintenance Screens

See [Figure 2-23](#). The information displayed on the maintenance screens can be used to identify, diagnose, and troubleshoot unit shutdown conditions and poor unit performance.

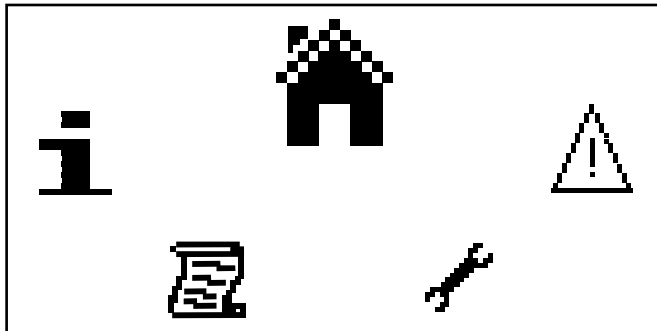

003779

Figure 2-23. Maintenance Screens

Icon	Description
	Home screen
	Alarms screen
	Maintenance screen

Icon	Description
	Event log screen
	About screen

Proceed as follows to enter the navigation menu:

1. Press both the ↑ and ↓ buttons simultaneously.
2. To select the required icon, press the ↑ button to cycle right and the ↓ button to cycle left until the desired operator screen section is reached.
3. Press the Select (✓) button to enter the desired operator screen section.

NOTE: Every time the operator screens are entered, the home icon will be located at the top of the screen.

Home Screens

See [Figure 2-24](#). The Home (🏠) screen is the default screen of the controller and displays after the controller has powered up. The controller automatically returns to Home screen from any other screen after a period of inactivity.

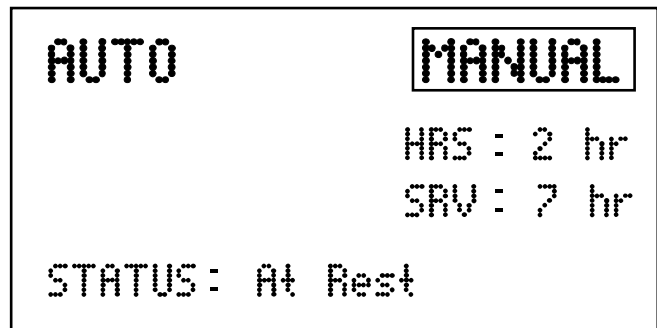

002544

Figure 2-24. Home Screen (MANUAL Mode Shown)

Alarms Screen

See [Figure 2-25](#). The Alarms (⚠️) screen displays all the alarms, warnings, and engine Diagnostic Trouble Code (DTC) faults. When an alarm occurs, the controller automatically switches to this screen and remains there until the alarm is cleared. The Stop LED also flashes.

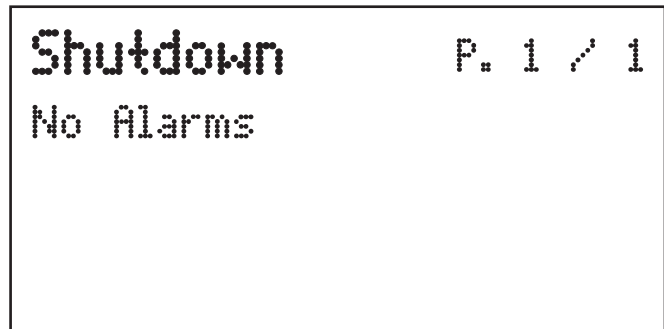

003780

Figure 2-25. Alarms Screen

- **Warnings** are non-critical alarm conditions and do not affect the operation of the generator system. They serve to draw the operator’s attention to an undesirable condition. By default, warning alarms are self-resetting when the fault condition is removed.
- **Electrical trips** stop the generator in a controlled manner. On initiation of the electrical trip condition, the controller de-energizes all the outputs, including the lights, to remove the load from the generator. Once this has occurred, the controller starts the cooling timer and allows the engine to cool off-load before shutting down the engine.
- **Shutdown alarms** stop the generator immediately. On initiation of the shutdown condition, the controller de-energizes all the outputs, including the lights, to remove the load from the generator. Once this has occurred, the controller shuts the generator set down immediately to prevent further damage.
- **DTC faults** are displayed by the controller.

Table 2-1. Possible DTC Faults

Fault	DTC Description
Check Engine Fault	A fault not recognized by the controller has been detected. Contact the engine manufacturer for support.
Low Oil Pressure	Engine oil pressure has fallen below its configured low oil pressure alarm level.
Underspeed	Engine speed has fallen below its configured underspeed alarm level.
Overspeed	Engine speed has risen above its configured overspeed alarm level.
Low Fuel Level	Engine’s fuel level has fallen below its configured low fuel level alarm.
Battery Under/Over Voltage	Engine’s DC supply has fallen below or risen above its configured alarm level.

To view the active alarms, repeatedly press the ↑ and ↓ buttons until the LCD window displays the alarm.

Continue to press the ↑ and ↓ buttons to cycle through the alarms.

To exit the alarm screen, press the ↑ and ↓ buttons simultaneously to enter the navigation menu. Once entered, cycle to the desired operator screen.

NOTE: The alarm condition must be corrected before a reset will take place. If the alarm condition remains, it is not possible to reset the unit. The exception to this is the Low Oil Pressure alarm and similar ‘active from safety on’ alarms, as the oil pressure is low with the engine at rest.

To clear alarms that stop the generator, refer to [Resetting the Maintenance Alarms \(If Equipped\)](#).

NOTE: The LCD backlight is on if the unit has sufficient voltage while the unit is turned on, unless the unit is cranking. In this case, the backlight is turned off.

If the controller is left in STOP mode for a period of inactivity, the controller enters POWER SAVE mode. To ‘wake’ the controller, press the Stop (O) button.

Maintenance Screen

See [Figure 2-26](#). The Maintenance screen (🔧) displays the maintenance alarms configured into the controller. The three alarms are for servicing the fuel filter, oil filter, and air filter.

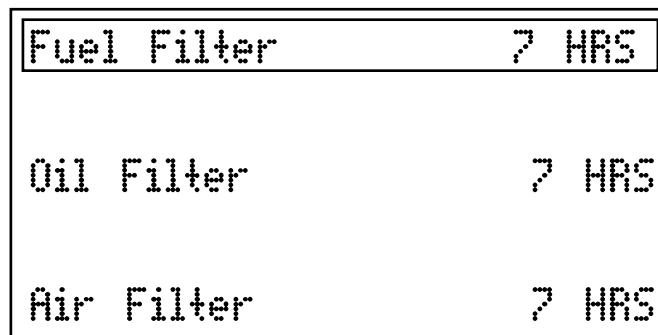

003781

Figure 2-26. Maintenance Screen

Event Log Screen

See [Figure 2-27](#). The controller’s event log (📖) displays a list of the last 15 recorded electrical trips or shutdown events and the engine hours at which they occurred. Once the log is full, any subsequent electrical trip or shutdown alarm overwrites the oldest entry in the log. The log always contains the most recent shutdown alarms.

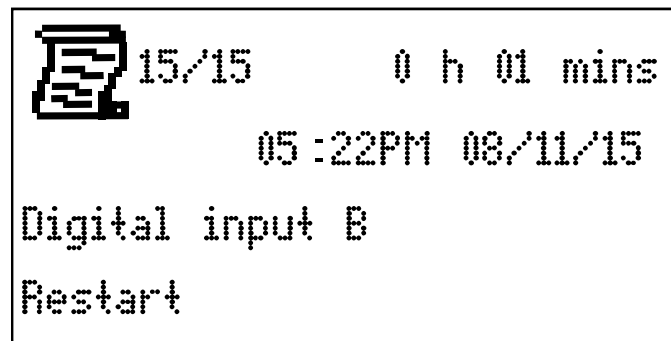

003782

Figure 2-27. Event Log Screen

Proceed as follows to view the event log:

1. Press both ↑ and ↓ buttons simultaneously to display the navigation menu.
2. Cycle to the event log section and press the Auto button to enter.

3. Repeatedly press the ↑ or ↓ buttons until the LCD window displays the desired event.

Continuing to press down the ↑ or ↓ buttons will cycle through past alarms. Eventually the most recent alarm will display and the cycle begins again.

To exit the event log, press the ↑ and ↓ buttons simultaneously to enter the navigation menu. Once entered, cycle to the desired operator screen.

About Screen

See [Figure 2-28](#). The About (i) screen contains information about the controller such as the controller's date and time, the product and USB identification number, and the application and engine version.

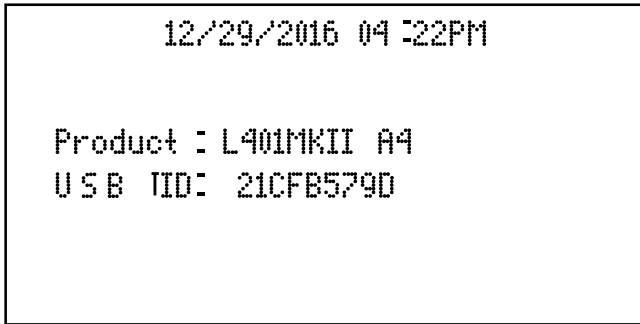

003783

Figure 2-28. About Screen

Section 3: Operation

Light Tower Setup

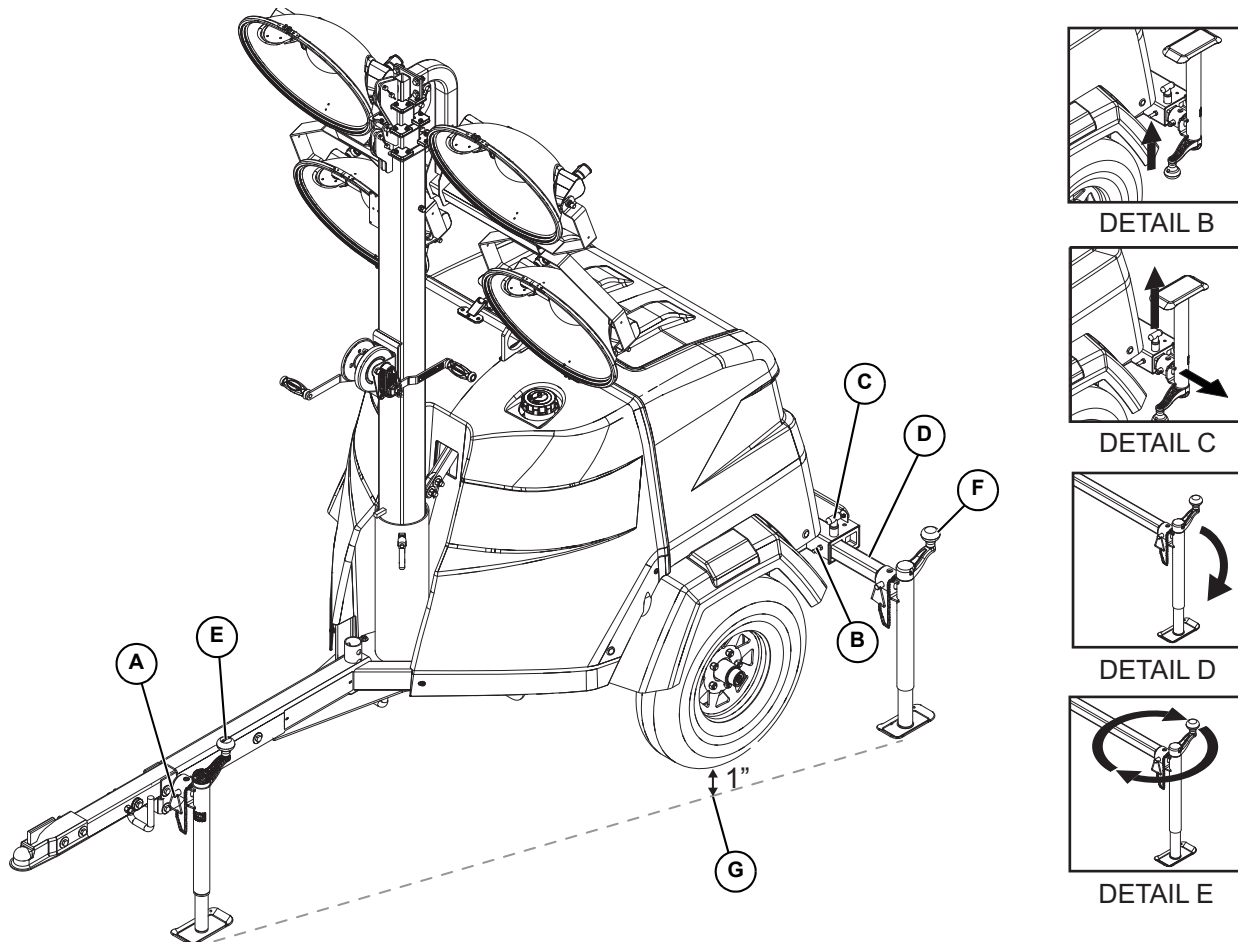

Figure 3-1. Set Up Outriggers and Jacks

006454



⚠ DANGER

High Voltage. Verify area above unit is clear of overhead wires and obstructions. Contact with high-voltage power lines will result in death or serious injury. (000260a)



⚠ WARNING

> 60 mph Do not set up the unit if high winds are expected. High winds can cause the unit to tip or fall, causing severe injury or machine damage. (000297)

1. For maximum light coverage, position the unit at ground level or in a spot higher than the area being illuminated by the lamps.

NOTE: The mast extends up to 23 ft (7 m).

2. Place the unit on firm ground that is relatively flat (less than 5° slope), and then block the wheels to prohibit movement. This will make it easier to level the unit.
3. See **Figure 3-1**. Pull the locking pin (A) on the tongue jack (E) and rotate the jack 90°. Reinstall the locking pin. Rotate the jack handle clockwise to raise the trailer tongue off the towing vehicle.
4. A grounding stud (B) is located on the rear frame of the trailer near the left side outrigger. For grounding requirements, follow local, state, or National Electrical Code (NEC) guidelines.
5. See Details C—D. Pull the locking pins (C) on the outriggers (D) and pull each outrigger out until the spring loaded locking pin snaps back into place. Pull the locking pin on each outrigger jack (F) and rotate each jack 180° so the jack pad is facing down. Reinstall the locking pin.

6. See Detail E. Rotate each jack handle clockwise to start leveling the trailer. Adjust all three jacks by rotating their handles clockwise until they are firmly in contact with the ground. Continue until the wheels are approximately 1 in (2.5 cm) off the ground (G).
7. Before raising the mast, it may be necessary to adjust the lamps. The lamps may be adjusted up, down, left, or right by aiming them in the desired direction.

Raising the Mast—Manual Winch



⚠ DANGER

Electrocution. DO NOT use the unit if electrical cord is cut or worn through. Doing so will result in death or serious injury. (000263a)

⚠ WARNING

Tipping hazard. Extend the outriggers and level the unit before raising the mast. Keep the outriggers extended while the mast is up. Failure to do so could cause the unit to tip and fall and could result in death or serious injury. (000266)

⚠ WARNING

Tipping hazard. Do not extend the mast beyond the colored mark on the second mast section. The unit can become unstable and tip or fall, causing injury. (000262)

⚠ WARNING

Personal Injury. Stop immediately if the mast hangs up or the winch cable develops slack. Excess slack could cause the mast to collapse, resulting in personal injury or equipment damage. (000265)

⚠ WARNING

Personal injury or equipment damage. Do not raise or lower the mast while the unit is operating. Doing so can break the lenses and cause the lamps to shatter. (000279)

1. Set up and level the unit. See [Light Tower Setup](#).
2. See [Figure 3-2](#). Inspect the mast cables for excessive wear or damage. Verify the cables are properly centered in each pulley (A). Inspect the electrical cord for damage.
3. Rotate the mast by loosening the mast rotation knob (C) at the bottom of the mast. Turn the mast until the lights face in the desired direction. Tighten

the mast rotation knob to secure the mast in position.

4. Using both hands, rotate the winch (B) to slowly extend the mast. Verify the coiled electrical cord is extending at the top sections of the mast. Stop extending the mast when the colored mark (D) on the second mast section is visible as seen in Detail D.

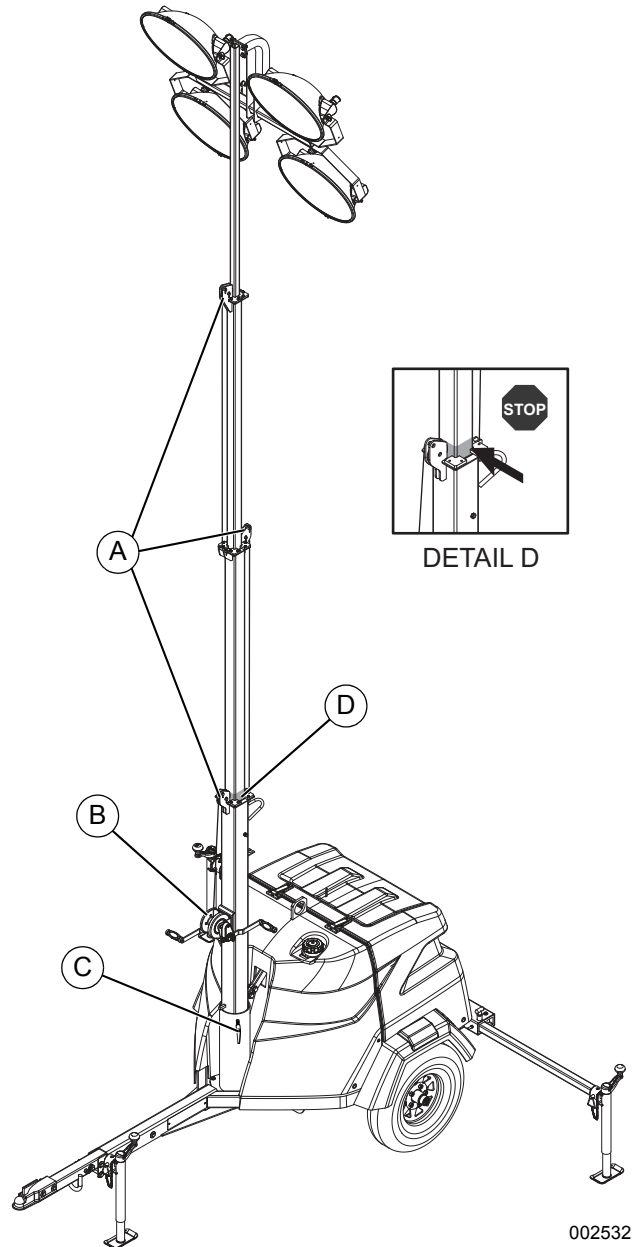

Figure 3-2. Pulley Locations—Manual Winch

IMPORTANT NOTE: Contact a GMP ASD immediately if the mast hangs up or the winch cable develops slack.

Raising the Mast—Electric Winch (If Equipped)



DANGER

Electrocution. DO NOT use the unit if electrical cord is cut or worn through. Doing so will result in death or serious injury. (000263a)

WARNING

Tipping hazard. Extend the outriggers and level the unit before raising the mast. Keep the outriggers extended while the mast is up. Failure to do so could cause the unit to tip and fall and could result in death or serious injury. (000266)

WARNING

Tipping hazard. Do not extend the mast beyond the colored mark on the second mast section. The unit can become unstable and tip or fall, causing injury. (000262)

WARNING

Personal Injury. Stop immediately if the mast hangs up or the winch cable develops slack. Excess slack could cause the mast to collapse, resulting in personal injury or equipment damage. (000265)

WARNING

Personal injury or equipment damage. Do not raise or lower the mast while the unit is operating. Doing so can break the lenses and cause the lamps to shatter. (000279)

1. Set up and level the unit. See [Light Tower Setup](#).

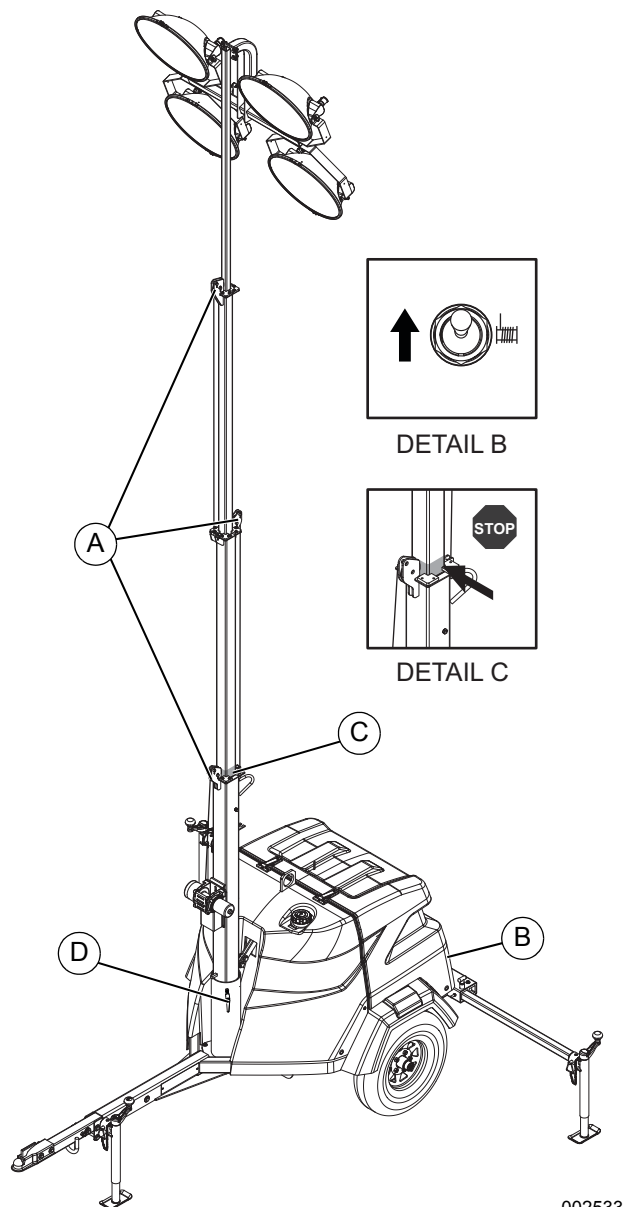

002533

Figure 3-3. Switch & Pulley Locations—Electric Winch

2. See [Figure 3-3](#). Inspect the mast cables for excessive wear or damage. Verify the cables are properly centered in each pulley (A). Inspect the electrical cord for damage.
3. Rotate the mast by loosening the mast rotation knob at the bottom of the mast (D). Turn the mast until the lights face in the desired direction. Tighten the mast rotation knob to secure the mast in position.

NOTE: On Key Switch models, key must be in RUN position to operate electric winch.

4. Press and hold the winch control switch (Detail B) upward to telescope the mast to the desired height. While doing so, verify that the coiled electrical cord

is extending at the top sections of the mast. Stop extending the mast when the colored mark (C) on the second mast section is visible as seen in Detail C.

IMPORTANT NOTE: A limit switch on the main mast section will disconnect power to the electric winch to prevent overextending the mast.

IMPORTANT NOTE: Contact a GMP ASD immediately if the mast hangs up or the winch cable develops slack.

Raising the Mast—Power Zone-DLA (If Equipped)



⚠ DANGER

Electrocution. DO NOT use the unit if electrical cord is cut or worn through. Doing so will result in death or serious injury. (000263a)

⚠ WARNING

Tipping hazard. Extend the outriggers and level the unit before raising the mast. Keep the outriggers extended while the mast is up. Failure to do so could cause the unit to tip and fall and could result in death or serious injury. (000266)

⚠ WARNING

Tipping hazard. Do not extend the mast beyond the colored mark on the second mast section. The unit can become unstable and tip or fall, causing injury. (000262)

⚠ WARNING

Personal Injury. Stop immediately if the mast hangs up or the winch cable develops slack. Excess slack could cause the mast to collapse, resulting in personal injury or equipment damage. (000265)

⚠ WARNING

Personal injury or equipment damage. Do not raise or lower the mast while the unit is operating. Doing so can break the lenses and cause the lamps to shatter. (000279)

NOTE: Units with the Power Zone-DLA do not have a mast switch for the electric winch.

1. Set up and level the unit. See [Light Tower Setup](#).
2. Turn the control power switch to on.

3. See [Figure 2](#) and [Figure 3-5](#). Press the up/down arrows (A) until the mast screen is shown.

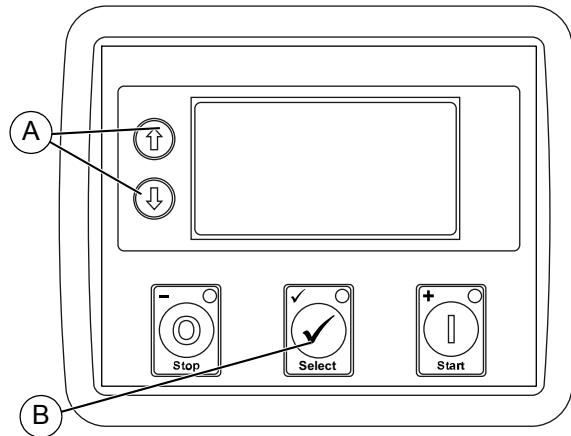

002353

Figure 3-4. Power Zone Controller

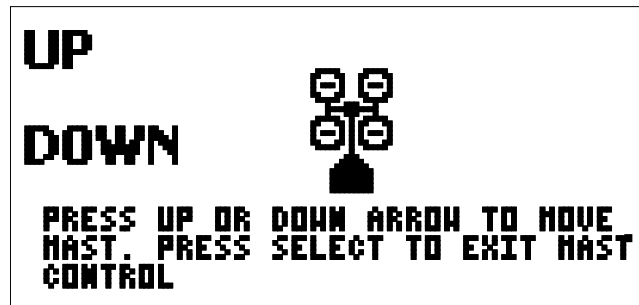

Figure 3-5. Raising the Mast Screen

4. Press the SELECT button (B); the UP/DOWN on the display will begin to flash. Press the arrows as needed until the mast is at the desired height. See [Figure 3-3](#). Do not extend past the colored mark (C).
5. Press SELECT again to exit the mast control screen.

IMPORTANT NOTE: Contact a GMP ASD immediately if the mast hangs up or the winch cable develops slack.

Prestart Checklist

Before starting the unit, all items in the prestart checklist must be completed. This checklist applies to both manual and remote starting of the unit.



⚠ WARNING

Consult Manual. Read and understand manual completely before using product. Failure to completely understand manual and product could result in death or serious injury. (000100a)

- Verify all maintenance procedures are up to date. For more information, refer to **General Maintenance** and **Basic Maintenance Schedule**.
- Perform a walk-around inspection. Refer to **Daily Walk-Around Inspection**.
- The unit must be level.
- The unit must be dry. Inspect for water inside or near the unit; dry if needed.
- For grounding requirements, follow the National Electrical Code (NEC), state, and local regulations.
- Verify the control power switch is OFF (O).
- Verify all circuit breakers are OFF (O).
- Inspect all electrical cords; repair or replace any that are cut, worn, or bare.
- Verify all winch cables are in good condition and centered on each pulley. Do not use if cables are kinked or beginning to unravel.
- Check oil, coolant, and fuel levels. For more information, refer to **General Maintenance**.
- Verify battery connections are secure.
- Turn the battery disconnect switch on, if equipped.
- Inspect the engine fan belt tension and condition.
- Inspect the engine fan belt guard.
- Inspect the engine exhaust system for loose or rusted components.
- Verify all covers are in place and secure.

Starting the Unit (Key Switch Models)

⚠ CAUTION

Equipment Damage. Do not continuously crank engine for more than ten seconds. Doing so will lead to overdischarge of batteries and starter seizure.

(000230)

NOTE: If the engine was run out of fuel or the fuel tank was drained, it may be necessary to purge the fuel lines. Refer to the engine operator's manual supplied with the unit.

1. See **Figure 3-6**. Verify the main circuit breaker and individual circuit breakers for each of the lights are OFF (O).

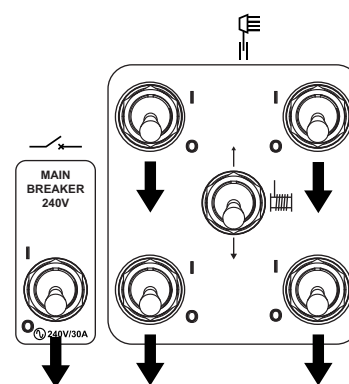

004386a

Figure 3-6. Circuit Breakers in OFF (O) Position

2. See **Figure 3-7**. Turn the key on the Engine Start switch to the right GLOW PLUG position and hold the key in place for five seconds.

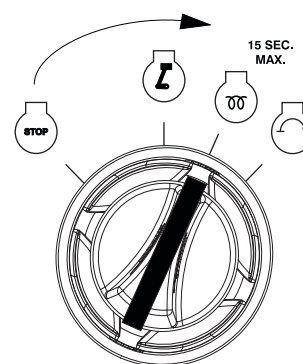

Figure 3-7. Activate Glow Plug

- See [Figure 3-8](#). Turn the key to the right START position and hold it until the engine cranks and starts running.

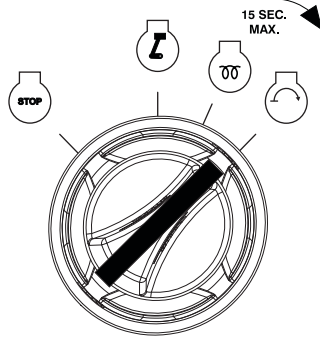

Figure 3-8. Crank Engine

- See [Figure 3-9](#). Release the key, it will move to the RUN position.

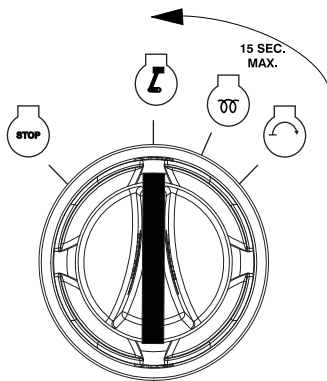

Figure 3-9. Release Key

Preparing for Start-Up (Power Zone–DLA)

NOTE: If the engine was run out of fuel or the fuel tank was drained, it may be necessary to purge the fuel lines before starting. Refer to the engine manual supplied with the unit.

Select AUTO or MANUAL Mode

See [Figure 3-10](#). Using the arrows on the Power Zone–DLA, select either AUTO or MANUAL on the Home screen.

- AUTO mode is required for programming automatic start and stop times (see [Scheduler Screen](#)), or enabling the “dusk to dawn” sensor (see [Dusk to Dawn Sensor \(Power Zone–DLA\) \(If Equipped\)](#)).
- MANUAL mode is used for on-demand control of the lights and convenience receptacles.

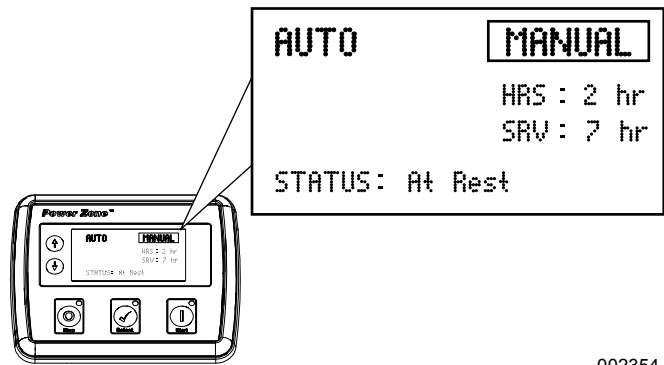

002354

Figure 3-10. Select AUTO or MANUAL Mode

Manually Starting the Unit

STOP mode is the default start-up setting for all units equipped with the Power Zone–DLA. Proceed as follows to start the generator in MANUAL mode.

- Verify the 240VAC outlet breaker is set to OFF (O).
- Set the main circuit breaker ON (I).
- When the controller powers up, the Home screen displays on the LCD screen and the Stop LED illuminates to indicate that the controller is in STOP mode. Press the Start button to initiate the startup procedure. If there are no existing engine faults, the engine will start and the Start LED will illuminate.

NOTE: The engine can be started from any screen. It may take a few seconds for the engine to run smoothly and reach its governed operating speed.

- If the engine does not start after the first cranking attempt, the engine will pause for 15 seconds to allow the starter to cool. The controller backlight will go out. The engine will make two more attempts to start for a total of three crank cycles.
- If the engine does not start and run within three starting cycles, the LCD screen will display the “Fail to Start” alarm. The starting sequence can be repeated after the starter cools for at least two minutes. Pressing the Stop (O) button will clear the alarm and reset the controller.

Light Operation (Key Switch Models)



WARNING

Burn hazard. Never operate lights with a damaged or missing lens cover. Lamps are hot and pressurized while in use. Unprotected lamps can shatter, causing severe injury.

(000277)

1. Verify the unit is ON and running smoothly.
2. See **Figure 3-11**. Switch the main circuit breaker (A) ON (I).
3. Switch the individual circuit breakers for the lights (B) ON (I), one at a time.

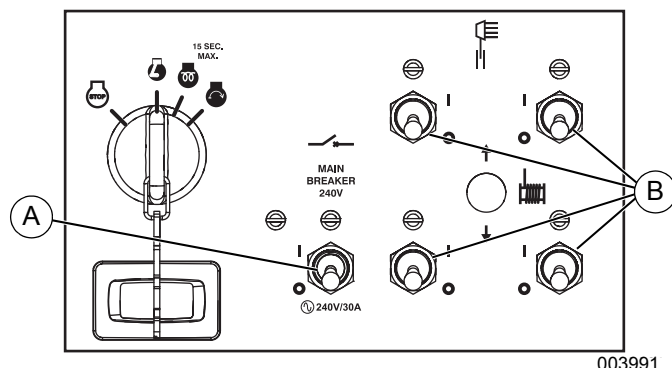

003991

Figure 3-11. Light Switches and Breaker

NOTE: The lights require a warm up period of 5–15 minutes before they reach full output. If the lights are shut down, they require a cool down period of approximately 10 minutes before they can be switched on again.

NOTE: The light tower uses four 1000W, 1050W or 1100W bulbs. When checking or replacing the bulbs, wipe them with a clean cloth to avoid leaving any grease, oil residue or fingerprints on the glass. Any residue can create a hot spot on the bulb, causing premature bulb failure.



WARNING

Burn hazard. Lamps become extremely hot while in use. Allow 10–15 minutes for cooling before handling or lowering mast. Touching a hot lens or fixture can cause severe burns.

(000278)

Light Operation (Power Zone–DLA) (If Equipped)

See **Figure 3-12**. The lights are turned on and off using the Power Zone–DLA. To view the light screen, press the ↑ button three times from the Home screen.

NOTE: The lights can only be turned ON and OFF while the unit is running in MANUAL mode. They operate automatically in AUTO mode.

1. Once the engine is up to temperature and running smoothly, switch the main circuit breaker ON (I).
2. To turn the light(s) ON, press the Select (✓) button. To turn the light(s) OFF, press the Select (✓) button.

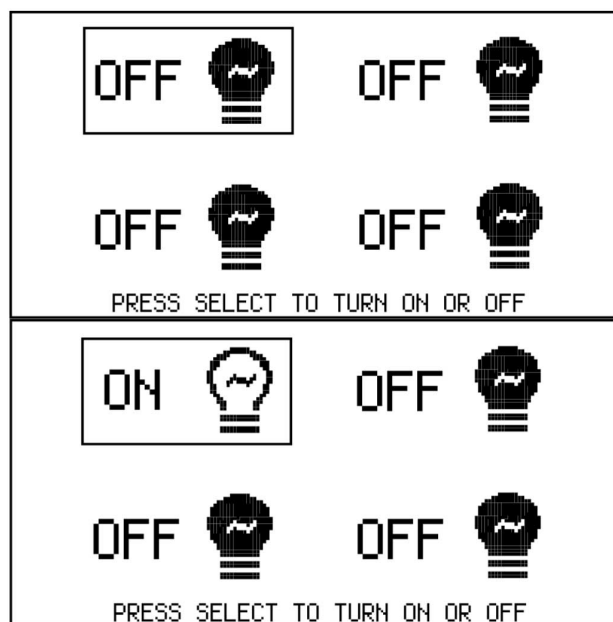

002327

Figure 3-12. Lights Screen



WARNING

Burn hazard. Lamps become extremely hot while in use. Allow 10–15 minutes for cooling before handling or lowering mast. Touching a hot lens or fixture can cause severe burns.

(000278)

Engine Derating

All units are subject to derating for altitude and temperature. Derating reduces the available power for operating tools and accessories connected to the receptacles. For every increase in 1,000 ft (305 m) of elevation, engine performance for this unit typically drops between 2–4%. Also, engine performance decreases about 1% for every 10 °F (5.6 °C) increase in ambient air temperature over 72 °F (22 °C).

Wet Stacking

The unit is powered by a diesel engine. Diesel engines are subject to “wet stacking” if lightly loaded. Wet stacking occurs when an engine is run at less than 30% of its full load capacity, causing unburned fuel to accumulate in the exhaust system. Wet stacking can be detected by continuous black exhaust when the unit is under a constant load. It can also cause fouling of injectors and buildup on engine valves. Diesel engines operate properly when applied loads are between 30–100% capacity. Appropriate generator sizing is determined by the anticipated load. If the unit is in a wet stack condition, load the unit heavily for five hours or until the exhaust is clear.

Dusk to Dawn Sensor (Power Zone–DLA) (If Equipped)

See **Figure 3-13**. If equipped with the Power Zone-DLA controller, this unit includes a “dusk to dawn” nightwatchman sensor (A) to detect the surrounding light level, automatically starting the engine and turning the lights on at dusk. The engine will run and the lights will remain illuminated until dawn.

To prepare the sensor for use, perform the following procedure at the time of day you want the lights to turn on:

1. Verify the Power Zone–DLA is set up and the unit is on.
2. Slide the light shield bracket up, decreasing the sensor’s exposure to light, until the lights turn on.
3. Tighten screws on shield.

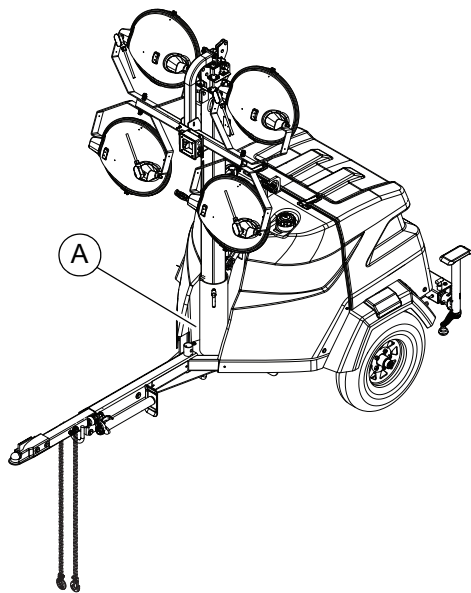

002528

Figure 3-13. Dusk to Dawn Sensor

Customer Convenience Receptacles

See **Figure 3-14**. The unit is equipped with convenience receptacles for powering accessories or tools from the generator. Power is supplied to the receptacles any time the engine is running and the main circuit breaker is switched to the ON (I) position. Each receptacle has an individual circuit breaker, located on the control box. Refer to **Control Panel**.

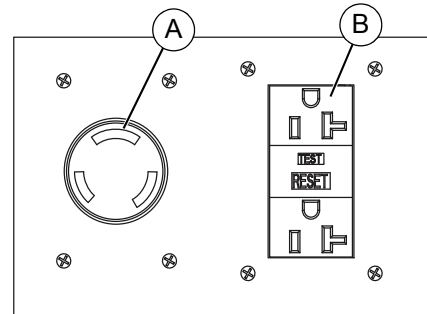

002535

Figure 3-14. Convenience Receptacles

The circuit breakers are labeled with the corresponding voltage for the receptacle they protect. The standard receptacle panel is equipped with the following receptacles:

- One 240V/30A Twist-lock (A)
- One 120V/20A GFCI (B)

NOTE: Do not draw more than 800W from each receptacle when 1100W bulbs are equipped, 1000W when 1050W bulbs are equipped, and 900W when 1000W bulbs are equipped. the lights are on. This will overload the generator and cause the main circuit breaker to trip. If the breaker trips, switch off the lights, remove some of the loads connected to the receptacles and wait 10 minutes for the bulbs to cool before turning them back on.

With the lights off, the full generator output may be used with the 240V twist-lock receptacle.

Shutting Down the Unit

Verify with personnel using power supplied by the unit and notify them power will be turned off. Verify the power shutdown will not create any hazards by accidentally turning off equipment that needs to remain running (pumps, compressors, lights, etc.).

1. Remove all loads from the receptacles.
2. Switch the individual circuit breakers for each light OFF (O).
3. Switch the main circuit breaker OFF (O).
4. Move the control power switch to STOP.

Shutting Down the Unit (Power Zone–DLA) (If Equipped)

Verify with personnel using power supplied by the unit and notify them power will be turned off. Verify the power shutdown will not create any hazards by accidentally turning off equipment that needs to remain running (pumps, compressors, lights, etc.).

1. Remove all loads from the receptacles.
2. Turn the lights off using the controller.
3. Switch the main circuit breaker OFF (O).
4. Press the Stop (O) button.
5. After the unit shuts down, switch the control power switch OFF (O).

NOTE: Disconnect the battery if the unit will be stored for an extended period. Refer to the engine operator's manual for additional extended storage procedures.

Automatic Shutdown

This unit is equipped with a low oil pressure and high coolant temperature automatic shutdown system. This system automatically shuts off the fuel supply to stop the engine if oil pressure drops too low, or the engine exceeds normal operating temperature. Return the main circuit breaker to STOP to reset the unit after the cause of shutdown has been determined.

Lowering the Mast—Manual Winch



⚠ WARNING

Burn hazard. Lamps become extremely hot while in use. Allow 10–15 minutes for cooling before handling or lowering mast. Touching a hot lens or fixture can cause severe burns.

(000278)

1. Shut down the lights and engine. See [Shutting Down the Unit](#). Allow lights 10–15 minutes to cool.
2. Lower the mast.
3. Use the winch handles to collapse the mast to its lowest position. Verify the electrical cord does not get caught in, or pinched by, the mast while it is being lowered.

⚠ WARNING

Personal Injury. Stop immediately if the mast hangs up or the winch cable develops slack. Excess slack could cause the mast to collapse, resulting in personal injury or equipment damage.

(000265)

IMPORTANT NOTE: Contact a GMP ASD immediately if the mast hangs up or the winch cable develops slack.

4. See [Figure 3-15](#). If the unit is going to be moved, rotate the mast so the lights face the rear of the unit.

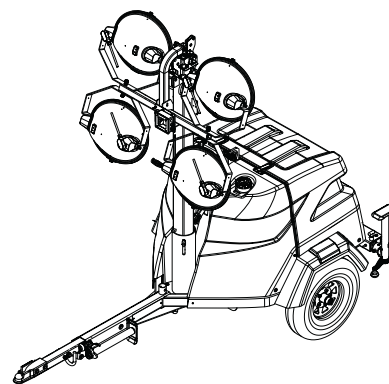

003990

Figure 3-15. Stowed (Travel) Position

To rotate the mast:

- a. Loosen the mast rotation knob.
- b. Rotate the mast until the white arrows are aligned and the metal stop tabs are touching.
- c. Tighten the mast rotation knob.

Lowering the Mast—Electric Winch (If Equipped)



⚠ WARNING

Burn hazard. Lamps become extremely hot while in use. Allow 10–15 minutes for cooling before handling or lowering mast. Touching a hot lens or fixture can cause severe burns.

(000278)

NOTE: On key switch models, key must be in RUN to operate electric winch.

1. Shut down lights and allow 10–15 minutes to cool.
2. Press and hold the upper winch control switch downward to collapse the mast to its lowest position. Verify the electrical cord does not get caught in, or pinched by, the mast while it is being lowered.
3. Shut down the engine. See [Shutting Down the Unit](#).
4. If the unit is going to be moved, rotate the mast so the lights face the rear of the unit. To rotate the mast:
 - a. Loosen the mast rotation knob.
 - b. Rotate the mast until the white arrows are aligned and the metal stop tabs are touching.
 - c. Tighten the mast rotation knob.

NOTE: The electric winch models are equipped with a safety limit switch. This switch disconnects power to the winch after the mast is completely raised or lowered. This prevents the cable from continuing to unwind and becoming entangled around the winch drum.

WARNING

Personal Injury. Stop immediately if the mast hangs up or the winch cable develops slack. Excess slack could cause the mast to collapse, resulting in personal injury or equipment damage. (000265)

IMPORTANT NOTE: Contact a GMP ASD immediately if the mast hangs up or the winch cable develops slack.

NOTE: If the light tower is not operational, and the batteries do not have enough power to lower the mast, it may be necessary to lower the mast manually. Always attempt to recharge the batteries and lower the mast electrically before proceeding.

Manually Lowering the Mast

IMPORTANT NOTE: Do not use this procedure unless it is absolutely necessary. Frequent use of this procedure could damage the motor shaft.

1. See [Figure 3-16](#). Remove the motor cover (A).

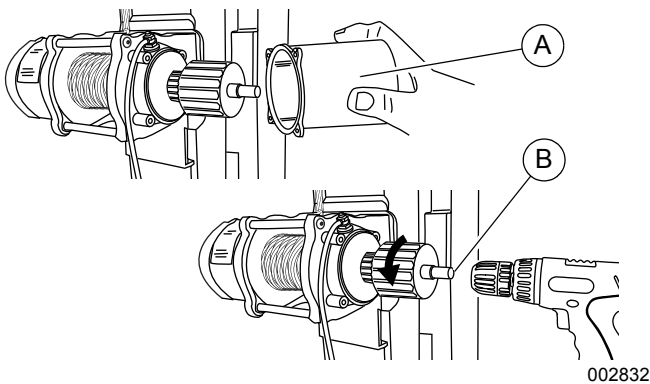

Figure 3-16. Manually Lowering the Mast

2. Attach a drill chuck firmly to the exposed motor shaft (B).
3. Using the drill, slowly rotate the motor shaft counterclockwise to lower mast.
4. Detach the drill chuck and install the motor cover after the mast is completely lowered.

Lowering the Mast—Power Zone-DLA (If Equipped)

NOTE: Units with the Power Zone-DLA do not have a mast switch for the electric winch.

1. Verify Power Zone-DLA controller is powered on.
2. Press the up/down arrows next to the controller display until the mast screen is shown. See [Figure 3-17](#).

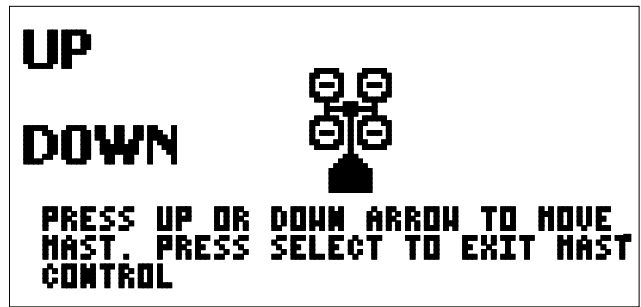

004765

Figure 3-17. Lowering the Mast Screen

3. Press the SELECT button; the UP/DOWN on the display will begin to flash. Press the down arrow as needed until the mast is lowered.
4. Press SELECT again to exit the mast control screen.

WARNING

Personal Injury. Stop immediately if the mast hangs up or the winch cable develops slack. Excess slack could cause the mast to collapse, resulting in personal injury or equipment damage. (000265)

IMPORTANT NOTE: Contact a GMP ASD immediately if the mast hangs up or the winch cable develops slack.

5. If the unit is going to be moved, rotate the mast so the lights face the rear of the unit. See [Raising the Mast—Manual Winch](#).

Positive Air Shutdown (PAS) (If Equipped)

See [Figure 3-18](#). This unit may be equipped with a positive air shutdown (A) on the air intake. The PAS system automatically stops the engine if an overspeed is detected. Engine overspeed can occur if the atmosphere contains elevated levels of combustible propane or natural gas.

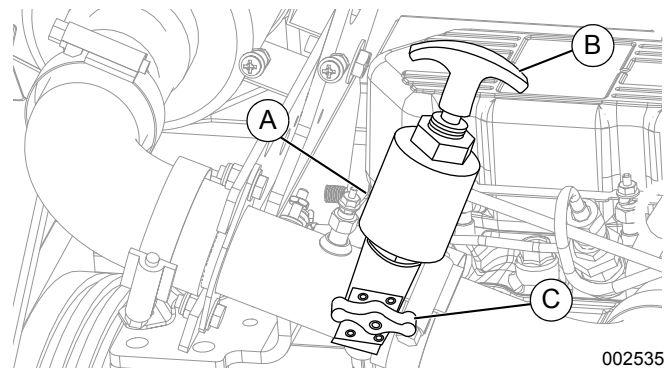

002535

Figure 3-18. Positive Air Shutdown

The PAS system stops the engine by closing an internal valve and obstructing intake air. Shutdown is triggered automatically by an output from the controller or manually by pulling the T-handle (B).

The reset knob (C) rotates 90° to block airflow. If the knob is parallel to the pipe centerline (as shown), the valve is open. If the knob is perpendicular to the pipe centerline, the valve is closed and airflow is blocked.

Test the PAS

Test the PAS at least once a month to ensure optimal valve performance. There are two methods:

1. Pull the T-handle. (**NOTE:** The valve must be open before testing.)
2. Press the emergency stop button.

Testing the PAS triggers an actuator, closing the butterfly valve inside the valve body. An audible click can be heard when the actuator engages. Confirm that the valve is closed by verifying that the knob has rotated perpendicular to the pipe centerline. If valve does not close, contact Generac Mobile Products Technical Support.

Reset the PAS

IMPORTANT NOTE: Before resetting the PAS, turn the control power switch OFF (O). This will prevent unexpected engine start-up during the procedure.

1. Rotate the reset knob and hold it in place while pulling the T-handle until reset knob rotates counterclockwise into plunger detent. An audible “click” indicates the reset knob has seated properly.
2. Verify that the reset knob is parallel to the intake pipe centerline.
3. Release T-handle, and then release reset knob. The reset knob should remain parallel to the intake pipe centerline.

Lower Radiator Hose Heater (If Equipped)

The lower radiator hose heater is designed to prevent engine coolant from freezing in extreme cold weather conditions. While the heater is designed to be operated overnight if necessary, 2–5 hours of heating just prior to starting is usually sufficient for proper engine starting.

NOTE: Use the lower radiator hose heater only in its designated location. Incorrect use can damage the engine.

Proceed as follows when operating a unit equipped with a lower radiator hose heater.

1. Verify the unit is level to maintain correct orientation of the heater while it is in operation.
2. Verify the cooling system is full of the correct mixture of water and engine coolant before each heater use.

3. Use only an undamaged, outdoor rated, three-prong grounded 120VAC extension cord with a minimum amperage rating of 10A. Connect the cord to a properly grounded 120VAC GFCI outlet.
4. Before starting the engine, unplug the extension cord from the power first, then unplug the heater cord set from the extension cord.

Tandem Tow (If Equipped)

See [Figure 3-19](#). The tandem tow hitch option (A) allows the operator to tow a second MLT6 Light Tower in series behind the unit equipped with the hitch.

IMPORTANT NOTE: Never tow more than two units at once.

- Connect any trailer wiring to the unit in front (B). Inspect for proper operation of the directional and brake lights.
- Connect the towing chains to the tie down locations (C).
- Avoid sharp turns when towing. **Do not** cross any obstacles more than 12 in (30.5 cm) deep.
- Tandem tow speeds:
 - a. Paved highway—45 mph (72 km/h)
 - b. Graded gravel—25 mph (40 km/h)
 - c. Cross country—10 mph (16 km/h)

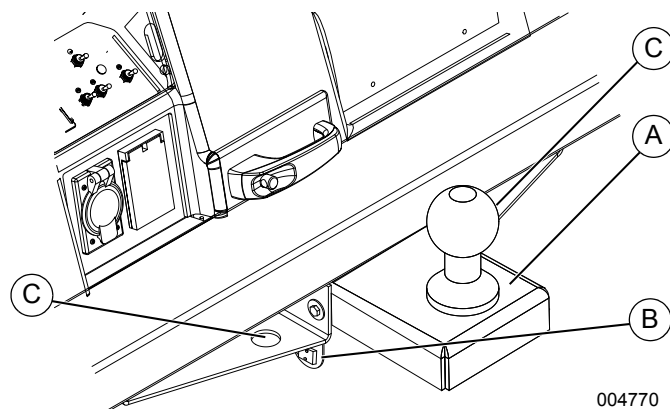

Figure 3-19. Tandem Tow

Telemetry (If Equipped)

The digital telemetry option enables the operator to remotely monitor the unit fuel level. A transmitter inside the engine compartment sends real time equipment status information to the user via cellular or satellite connection.

Spark Arrester (If Equipped)

A spark arrester, installed on the unit exhaust, may be required by code in certain municipalities. Contact the local authority having jurisdiction to determine if a spark arrester must be installed on the unit before operation.

Heated Fuel Filter (If Equipped)

See [Figure 3-20](#). An optional heated fuel filter (A) prevents diesel fuel from gelling in extremely cold temperatures. Heating cycles are automatically controlled by the Power Zone–DLA.

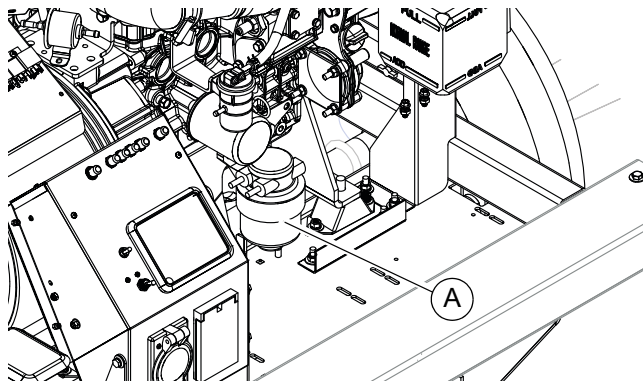
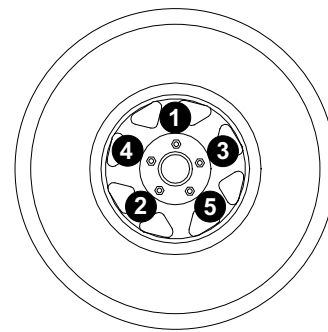

Figure 3-20. Heated Fuel Filter

Towing the Unit

Once the engine is shut down and the mast and lights are correctly stowed, proceed as follows to prepare the unit for towing.

1. Raise the outrigger jacks completely and release the locking pins to rotate them up into the travel position. Verify the locking pins snap into place. Release the outrigger locking pins and slide the outriggers into the trailer frame until the locking pins snap into place.
2. Use the tongue jack to raise or lower the trailer onto the hitch of the towing vehicle. Lock the hitch coupling and attach the safety chains or cables to the vehicle. Remove the tongue jack locking pin and rotate the jack into the travel position. Replace the locking pin.
3. To ensure correct operation of the jacks, refer to [Trailer Wheel Bearings](#). For maintenance interval information, refer to [Basic Maintenance Schedule](#).
4. Connect any trailer wiring to the tow vehicle. Inspect for correct operation of the directional and brake lights.
5. Verify the enclosure is correctly latched.
6. Check for correct inflation of the trailer tires. For maximum tire pressures, refer to [Specifications](#).
7. See [Figure 3-21](#). Inspect the wheel lugs. Tighten or replace any lugs that are loose or missing. If a tire has been removed for axle service or replaced, tighten the lugs, in the order shown, to the following specifications:



003754

Figure 3-21. Tightening Wheel Lugs

- a. Start all lug nuts by hand.
- b. First pass: tighten to 20-25 ft-lbs (27-33 Nm).
- c. Second pass: tighten to 50-60 ft-lbs (67-81 Nm).
- d. Third pass: tighten to 90-120 ft-lbs (122-162 Nm).

NOTE: After the first road use, torque the lug nuts in sequence.

8. Maximum recommended speed for highway towing is 45 mph (72 km/h). Recommended off-road towing speed is not to exceed 10 mph (16 km/h) or less, depending on the terrain.

Lifting the Unit

Proceed as follows to prepare the unit for lifting:

1. Verify the equipment being used to lift the unit is in good condition and has sufficient capacity. For approximate weights, refer to [Specifications](#).
2. Close and lock all hoods and doors.
3. See [Figure 3-22](#). Stow the mast and lights in the travel position as shown.
4. Always remain aware of people and objects around the unit while preparing, maneuvering, and lifting the unit.
 - When lifting the unit, attach any slings, chains, or hooks directly to the central lift point (A). The central lift point is located on top of the enclosure, connected to a lift structure inside the unit.

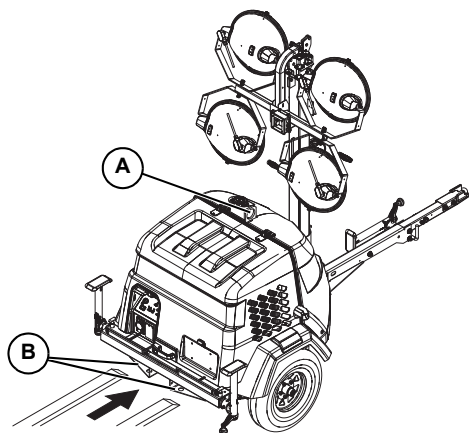

006456

Figure 3-22. Lifting Points

- Use the forklift pockets (B) with care. Lift directly from the rear. Avoid approaching the unit at an angle, as this can permanently damage the forklift pockets, tires, or cabinet. Verify any obstructions are clear of the forklift tines before lifting.

Tying the Unit Down

When securing the unit for transportation, verify the equipment being used to fasten the unit is in good condition and has sufficient strength to hold the unit in place during transport.

See [Figure 3-23](#). Use the tie-down points (C) as shown.

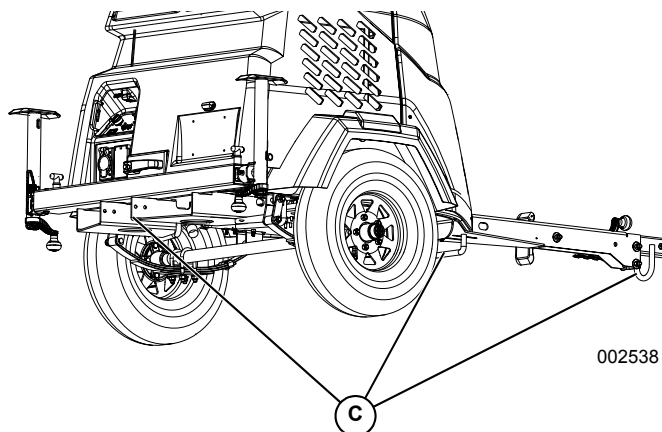

002538

Figure 3-23. Tie-Down Points

This page intentionally left blank.

Section 4: Maintenance

Emissions Information

For warranty information, please refer to the diesel engine manual supplied with this unit.

Daily Walk-Around Inspection



Equipment Damage. Failure to perform a daily inspection could result in damage to the unit.

(000306)

Perform a walk-around inspection of the unit every day before starting the unit. Look for conditions that could hinder performance or safety, such as (but not limited to):

- Oil, coolant, and fuel leakage
- Blocked vents
- Loose or missing hardware
- Loose or broken electrical connections

Inspect the fan belt for cracks, fraying, or stretching. Verify the belt is correctly seated in the pulley grooves. Replace the belt according to the manufacturer's recommendations.

General Maintenance

Poorly maintained equipment can become a safety hazard. In order for the equipment to operate safely and correctly over a long period of time, periodic maintenance and occasional repairs are necessary. **DO NOT** perform routine service (oil and filter changes, cleaning, etc.) unless all electrical components are shut off.

Regular maintenance will improve performance and extend engine/equipment life. Generac Mobile Products, LLC recommends that all maintenance work be performed by a GMP ASD. Regular maintenance, replacement or repair of the emissions control devices and systems may be performed by any repair shop or person of the owner's choosing. However, to obtain emissions control warranty service free of charge, the work must be performed by a GMP ASD or authorized Mitsubishi® engine dealer depending on the repair. See the emissions warranty.

Preparing for Service

Before servicing the unit, always follow the instructions listed below.

1. If unit is equipped with the Power Zone™-DLA controller, verify the main circuit breaker is OFF. Otherwise, verify the key switch is OFF.
2. Verify the circuit breakers are switched OFF (O).

3. Disconnect the negative (–) terminal on the battery.
4. Attach a "Do Not Start" sign to the control panel to signify that the unit is being serviced and reduce the chance of unauthorized use.

Cleaning the Unit



Equipment damage. Never spray water to clean unit. Do not introduce water into generator windings, terminals, or fuel system during the cleaning process. Doing so will result in equipment damage.

(000325a)

Always clean the unit after each use to remove dust, grease, mud, or spilled fuel or oil. Use soft, clean rags to wipe the cabinet exterior and control panel. Low-pressure compressed air (less than 40 psi [276 kPa]) can also be used to remove dust and debris from the cabinet interior.

This unit contains sensitive electronic components that can be damaged by high pressure and heat. **Do not:**

- wash the unit with a high pressure hose or power washer.
- wash the engine block or fuel tank with a power washer or steam cleaner. Water may enter the cabinet and collect in the generator windings or other electrical parts, causing damage.

Inspecting the Unit

- If the unit is stored outside, inspect for water inside the cabinet and generator before each use. If wet, dry the unit thoroughly before starting.
- Inspect condition of electrical cords. **DO NOT** use the unit if insulation is cut or worn through.
- Verify winch cables are in good condition and centered on each pulley. **DO NOT** use a cable that is kinked or starting to unravel.
- Verify the wheel lugs are present and correctly tightened. Refer to [Towing Safety](#).
- Check the coolant level daily by inspecting the level in coolant overflow jug located near the radiator. Refer to the engine operator's manual for coolant recommendations and proper mixture. Normal operating level is between the 'full' and 'add' markings on the overflow jug.
- After engine is stopped and completely cool, coolant may be added directly to the coolant overflow jug.
- Check the oil level daily. Refer to the engine operator's manual for the appropriate oil specification.

- Verify the oil is correct for special operating conditions such as a change in season or climate.
 - **DO NOT** start the unit if the engine oil level is below the ADD mark on the dipstick.
 - Normal operating level is in the cross-hatch pattern between the full and add markings on the dipstick.
 - Add oil only if the oil level is below the add mark on the bottom of the cross-hatch pattern on the dipstick. **DO NOT OVERFILL** the crankcase.
- Check the fuel level.
- If the unit is connected to a remote start or transfer switch, verify the remote switch is also off and tagged.

Refer to the engine operator’s manual supplied with the unit.

Basic Maintenance Schedule

Refer to the original equipment manufacturer’s operating manual for a complete list of maintenance requirements. Failure to comply with the procedures as described in the engine operator’s manual will nullify the warranty, decrease performance, and cause equipment damage or premature equipment failure. Maintenance records may be required to complete a warranty request.

Use the schedule in the following table as a guide for regular maintenance intervals. For additional or replacement copies of the engine operator’s manual, contact a GMP ASD.

NOTE: If the engine was run out of fuel or the fuel tank was drained, it may be necessary to purge the fuel lines.

Table 4-1. Basic Maintenance Schedule—MLT6SM (Mitsubishi)

Item	Daily	First 50 Hours	Every 750 Hours	As Required
Check oil level	◆			
Check coolant level	◆			
Check fuel level	◆			
Check tire pressure	◆			
Inspect wheel bearings	◆			
Inspect all electrical connections	◆			
Inspect radiator fins for debris; clean as required	◆			
Inspect light tower winch for proper operation	◆			
Replace engine oil and oil filter		◆	◆*	
Inspect and adjust belt and belt tension		◆	◆*	
Replace fuel filter		◆	◆	
Inspect battery condition			◆	
Replace air cleaner element			◆	
Lubricate leveling jacks				◆
Purge air from fuel system				◆
Drain residual water from fuel filter				◆

* *Generac Mobile Products, LLC recommends that oil change intervals on the MLT6SM equipped with the Mitsubishi L3E-W461ML Tier 4 engine be extended to 750 hours after initial break-in. The engine comes from the factory with a larger sump that holds 5.5 qts (5.2 L) of engine oil. After the initial 50 hour break-in and oil change, the sump, coupled with the larger oil filter, allows the engine to operate up to 750 hours between routine oil changes. Hot, humid, or dusty conditions can shorten engine oil service life, regardless of suggested oil change intervals. Always follow the recommendations of the OEM engine manual that was shipped with the unit for specific operating instructions. If further technical assistance is required, contact Generac Mobile Products Technical Service at 1-800-926-9768.*

Table 4-2. Basic Maintenance Schedule—MLT6SK (Kubota®)

Item	Daily	First 50 Hours	Every 500 Hours	Every 750 Hours	As Required
Check oil level	◆				
Check coolant level	◆				
Check fuel level	◆				
Check tire pressure	◆				
Inspect wheel bearings	◆				
Inspect all electrical connections	◆				
Inspect radiator fins for debris; clean as required	◆				
Inspect light tower winch for correct operation	◆				
Inspect fan belt for tightness	◆				
Inspect radiator hoses and clamp bands	◆				
Replace fan belt			◆		
Replace fuel filter element				◆	
Replace air filter element				◆*	
Replace engine oil and oil filter		◆		◆**	
Lubricate leveling jacks					◆
Remove sediment in fuel tank					◆
Clean air cleaner element					◆

* Replace the air cleaner element yearly, or after six cleanings, whichever occurs first.

** Generac Mobile Products, LLC recommends that oil change intervals on the MLT6SK equipped with the Kubota engine be extended to 750 hours after initial break-in. The engine comes from the factory with a larger sump that holds 5.5 qts (5.2 L) of engine oil. After the initial 50 hour break-in and oil change, the sump, coupled with the larger oil filter, allows the engine to operate up to 750 hours between routine oil changes. Hot, humid, or dusty conditions can shorten engine oil service life, regardless of suggested oil change intervals. Always follow the recommendations of the OEM engine manual that was shipped with the unit for specific operating instructions. If further technical assistance is required, contact Generac Mobile Products Technical Service at 1-800-926-9768.

Resetting the Maintenance Alarms (If Equipped)

The Power Zone-DLA controller will display a warning message when the unit is due for maintenance or service. The maintenance or service interval is set at 750 hours of engine running time. Once the unit has been serviced, the appropriate maintenance alarm reminder needs to be reset. Proceed as follows to reset the maintenance alarms:

1. With the unit shut down, set the control power switch to ON (I). After initialization, the controller will toggle automatically to the Home screen.
2. Press ↑ and ↓ simultaneously to enter the navigation menu.
3. Press ↑ or ↓ to move  to the top of the screen. Press ✓ to enter the Maintenance screen.
4. Press ↑ or ↓ to highlight the desired alarm that needs to be reset. Press ✓ to start reset.
5. Enter the pin 4444. To do this, press ✓ and then ↑ or ↓ to adjust the first number of the maintenance pin. Press ✓ to continue to the next number.

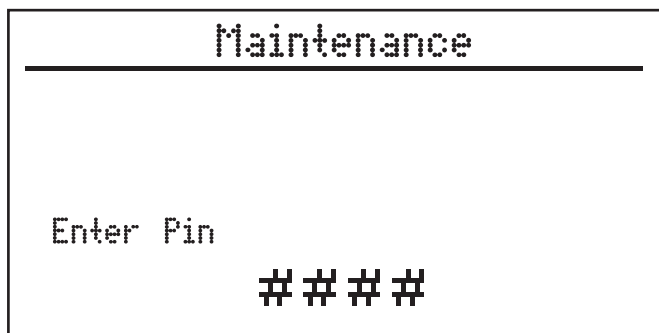

003784

Figure 4-1. Entering Maintenance Pin

Manual Winch: Use, Operation, and Maintenance

Prior to Use

- Inspect rope or cable and replace if damaged.
- Inspect mounting hardware for correct tightness and torque if necessary.
- Gears, ratchet pivot point, and shaft bushings must be kept lubricated with a thin film of oil or grease.

Operation

Raising the Lights:

1. The cable must be securely fastened to the winch drum.

2. Verify the cable and cable attachments are not damaged. Contact Generac Mobile Products, LLC to order a replacement cable if necessary.
3. Referring to the "Lift / Let Down" decal on the winch, turn handle according to the specified direction to lift. The ratchet MUST make a loud clicking sound while winding the cable.

Lowering the Lights:

Referring to the "Lift / Let Down" decal on the winch, turn handle according to the specified direction to lower. No clicking will be heard because the brake system is activated.

Maintenance

The following procedures should be performed at least annually:

1. The gears and bushings of the winch must be kept lubricated. Apply a thin film of grease to the gear teeth, and oil the bushings as needed.
2. The ratchet pawl pivot point must be kept lubricated with a thin oil.

NOTE: Do not get oil or grease on the brake mechanism.

Electric Winch (If Equipped): Use, Operation, and Maintenance

- Keep the winch free of dirt, oil, grease, water, and other substances.
- Check all mounting bolts and verify they are tightened to the recommended torque values. Replace any damaged fasteners.
- Periodically inspect all connections to verify they are tight and free of corrosion.
- Inspect the cable for visible damage every time the winch is operated. Examples of damage are: cuts, knots, crushed or frayed portions, and broken strands. Replace cable immediately if damaged. Failure to replace a damaged cable could result in breakage.
- Regularly inspect the brake for slippage or drift. This is detected visually when winch is under load. If winch drum continues to turn after controls are released, the brake may need to be replaced.
- Periodically clean and grease the brake assembly. This will ensure correct performance and extend the life of the winch. If winch seems to labor or get excessively hot during the lowering of loads, the brake will need to be serviced or replaced.
- Inspect motor brushes periodically and replace when necessary.

NOTE: Only the motor brushes and brake assembly require periodic replacement.

Winch Mechanical Brake

The mechanical brake generates heat when loads are lowered and the wire cable is powered out. Avoid overheating the mechanical brake. Overheating the mechanical brake may result in permanent damage to, or failure of, the brake. Replace any damaged brake components before resuming use of the winch.

Whine or chatter associated with a new mechanical brake is normal and typically disappears with use.

Overheating the mechanical brake may result in permanent damage to, or failure of, the brake. Replace any damaged brake components before resuming use of the winch.

Table 5: Winch Preventative Maintenance Schedule

Maintenance Activity	After First Operation	Before Each Use	Semi-Annually
Inspect fasteners	◆		◆
Inspect electrical connections	◆		◆
Clean and grease brake assembly			◆
Inspect motor brushes			◆
Inspect winch and control	◆	◆	◆

Trailer Wheel Bearings

The trailer axles are equipped with a Zerk grease fitting to allow lubrication of the wheel bearings without the need to disassemble the axle hub. Use only a high quality grease made specifically for lubrication of wheel bearings, such as Valvoline W615 or equivalent.

See [Figure 4-2](#). Proceed as follows to lubricate the wheel bearings:

The minimum recommended lubrication is every 12 months or 12,000 miles (19,312 km). More frequent lubrication may be required under extremely dusty or damp operating conditions.

Every six months, or depending on usage, check for play in each bearing by jacking up the trailer, then trying to rock the wheel. If further assistance is required, contact Generac Mobile Products Technical Service at 1-800-926-9768.

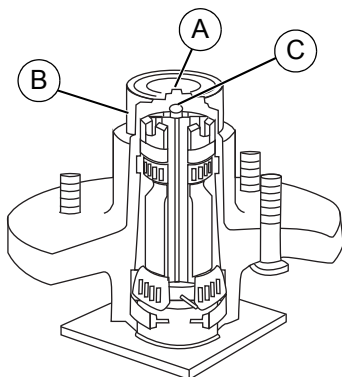

002540

Figure 4-2. Wheel Bearing Cross Section

1. Remove the small rubber plug (A) from the metal end cap (B).
2. Attach a standard grease gun fitting to the Zerk grease fitting (C).
3. Pump grease into the Zerk fitting until fresh grease is visible around the nozzle of the grease gun.
4. Wipe any excess grease from the axle hub with a clean cloth and replace the rubber plug.

Jack Maintenance

Before each use, inspect each jack foot for damage and remove any mud or debris. The jacks must be clean and in good operating condition to correctly support the unit.

This page intentionally left blank.

Section 5: Troubleshooting

General Troubleshooting



WARNING

Risk of burns. Allow engine to cool before draining oil or coolant. Failure to do so could result in death or serious injury.

(000139)

Some of the more common problems are listed in the table below. This information is intended to be a check or verification that simple causes can be located and fixed. It does not cover all types of problems. Refer to the OEM engine operator's manual for additional troubleshooting information. Procedures that require in-depth knowledge or skills should be referred to a GMP ASD.

Table 5-1. General Troubleshooting Guide

Problem	Possible Cause	Solution
Low oil pressure shutdown	Low oil level	Verify oil level on dipstick. Add oil, if needed.
	Oil leaking from engine	Inspect the engine for leaks.
	Oil pressure switch failure	Refer to OEM engine operator's manual to identify corrective action.
High coolant temperature shutdown	Low coolant level	Add coolant if needed. Allow engine to cool, then check coolant level in radiator. Restart engine and check coolant temperature. Stop engine immediately if coolant temperature is 210 °F (99 °C) or more.
	Blockage in radiator	Inspect radiator shroud and ducting for blockage and remove any foreign matter.
	Leakage in coolant hoses, engine block, or water pump	Inspect for visible leaks. Verify tension of water pump serpentine drive belt. Remove load on generator and restart engine. Verify coolant temperature and shut engine down immediately if it starts to overheat. Refer to the OEM engine operator's manual for additional information on engine overheating.
	Faulty thermostat	Contact a GMP ASD to replace.
	Water pump failure	Contact a GMP ASD to replace.
	Incorrect mix/frozen radiator	Thaw the radiator with an external heat source and flush the coolant system with the correct coolant mixture.
Unit cranks, but will not start	Low fuel level	Check fuel level in tank. Verify fuel pump operation.
	Restricted air filter	Inspect air filter for blockage. Refer to OEM engine operator's manual for additional information.
	PAS engaged	Verify PAS is off.

If problems persist, contact Generac Mobile Products, LLC at 1-800-926-9768 for assistance.

Troubleshooting the Lights



WARNING

Burn hazard. Lamps become extremely hot while in use. Allow 10–15 minutes for cooling before handling or lowering mast. Touching a hot lens or fixture can cause severe burns.

(000278)

IMPORTANT NOTE: Only a qualified electrician should troubleshoot or repair electrical problems occurring in this equipment. Contact Generac Mobile Products Technical Service at 1-800-926-9768 for assistance if you have any questions, or if problems persist.



WARNING

Electrocution. Potentially lethal voltages are generated by this equipment. Render the equipment safe before attempting repairs or maintenance. Failure to do so could result in death or serious injury.

(000187)

Problem	Possible Cause	Solution
Mast lights off, checking outside the control box	Light fixture is too hot	Allow light to cool 10–15 minutes before restarting.
	Faulty lamp connection	Verify lamp is tight in the socket.
	Lamp broken	Inspect for broken arc tube or outer lamp jacket, broken or loose components in lamp envelope, or blackening/deposits inside tube.
	Loose lighting connections	Inspect the connections inside the mast junction box and each mast light housing/socket.
	Damaged or loose electrical cord	Inspect the mast electrical cord for damage and check the cord connections inside the control box.
	Faulty fuel filter	With engine running and lights off, measure voltage and frequency at the GFCI receptacle. Voltage should indicate 120VAC ± 5%, and frequency should indicate 60.7 Hz ± 5%. If frequency and voltage are both low (<114VAC, <58 Hz), replace the fuel filter.
	Faulty generator capacitor	Measure the capacitance of the generator capacitor. If measurement is outside rating (as indicated on the capacitor), replace the capacitor.
Mast lights off, checking inside the control box	Loose lighting connections	Inspect the connections inside the control box and inside each ballast box.
	Generator output incorrect	Check the incoming voltage to the ballast by checking the available voltage on the GFCI receptacle. Incoming voltage should be 120V ± 5V. If voltage is incorrect, the generator may require service.
	Low transformer output	The voltage from the transformer should read approximately 400VAC as the light “strikes” (induces an arc), then drop and slowly rise back up to stabilize at 240-260VAC. On hard wired models, remove the mast junction box cover and insert the wire probes into the connector blocks for the light and ground. If proper voltage is not achieved, perform capacitor check to determine if the capacitor or coil needs to be replaced.
Mast lights on but the light output is low	Fixture and/or lens is dirty	Clean reflective surface inside fixture and both inside and outside surface of glass lens. Use mild soap and water to clean lens. Other chemicals may have an adverse effect on the glass.
	Lamp worn due to normal use	Replace lamp.
	Damaged or loose electrical connections	Inspect the mast coil cord, mast junction box, and mast light connections.
	Generator output incorrect	Check the incoming voltage to the ballast. Incoming voltage should be 120V ± 5V. If the voltage is incorrect, the generator may require service.
	Low transformer output	The voltage from the transformer should read approximately 400VAC as the light “strikes” (induces an arc), then drop and slowly rise back up to stabilize at 240–260VAC. On hard wired models, remove the mast junction box cover and insert the wire probes into the connector blocks for the light and ground. If proper voltage is not achieved, perform capacitor check to determine if the capacitor or coil needs to be replaced.

Section 6: Wiring Diagrams

Mast Junction Box Wiring and Light Connections

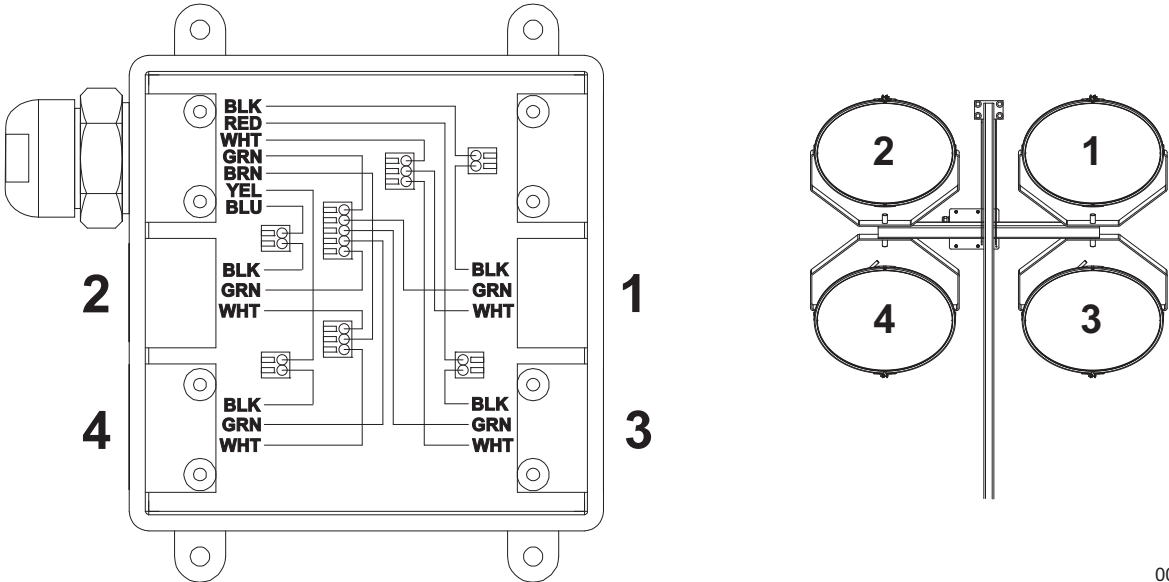

00768

AC Wiring Diagram

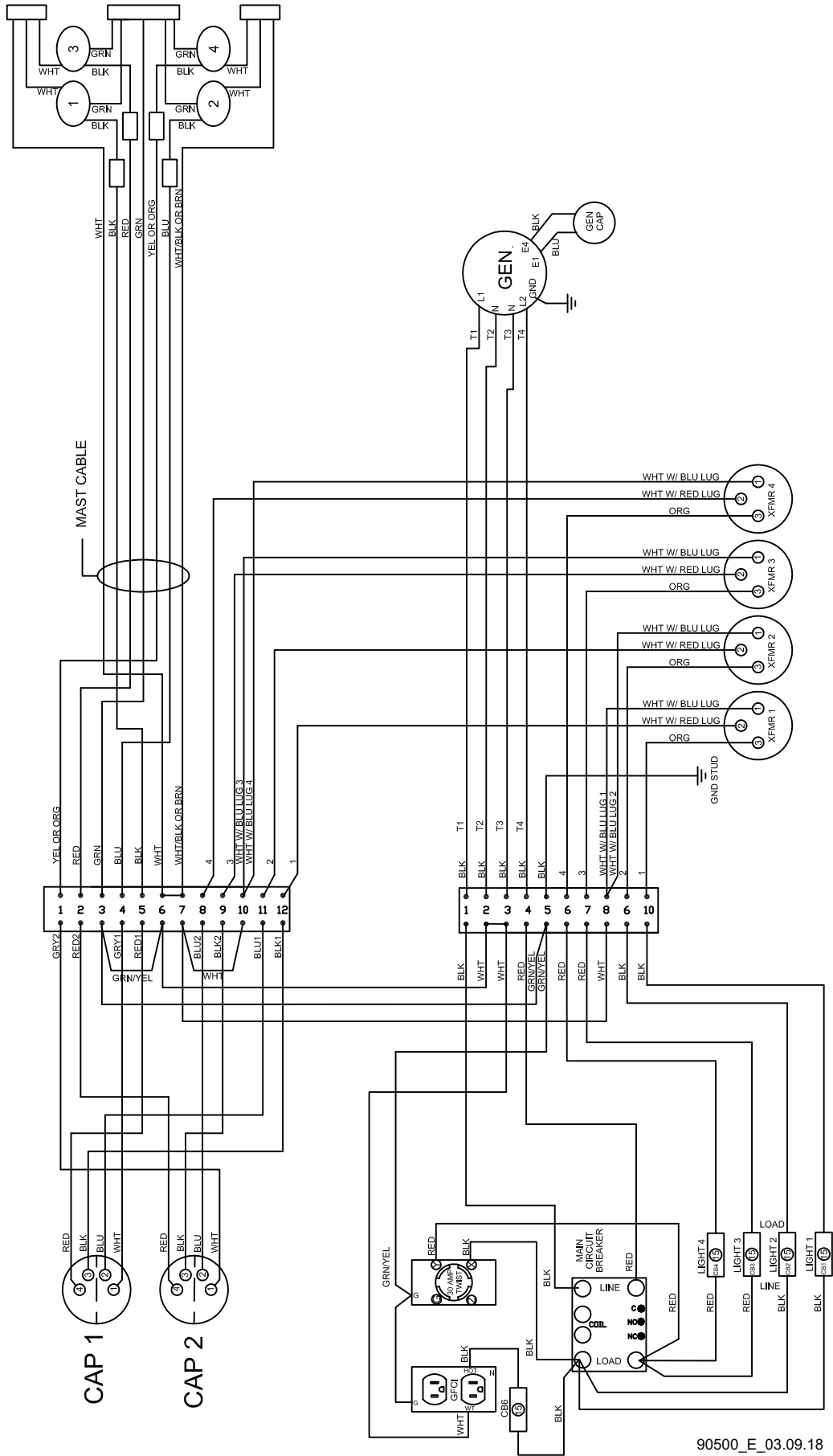

90500_E_03.09.18

AC Wiring Diagram—MLT6SK and MLT6SM Power Zone (If Equipped)

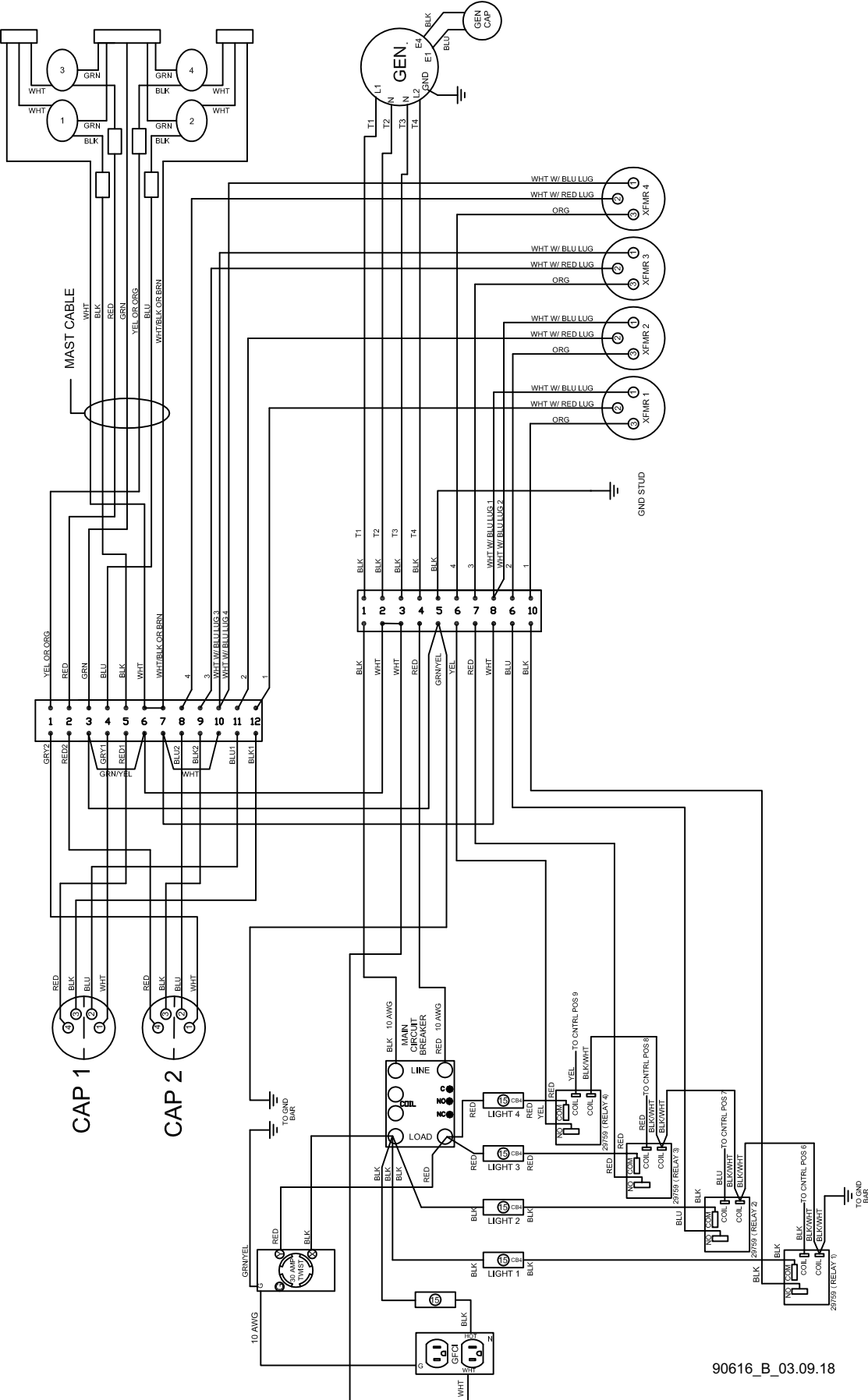

90616_B_03.09.18

DC Wiring Diagram—MLT6SM

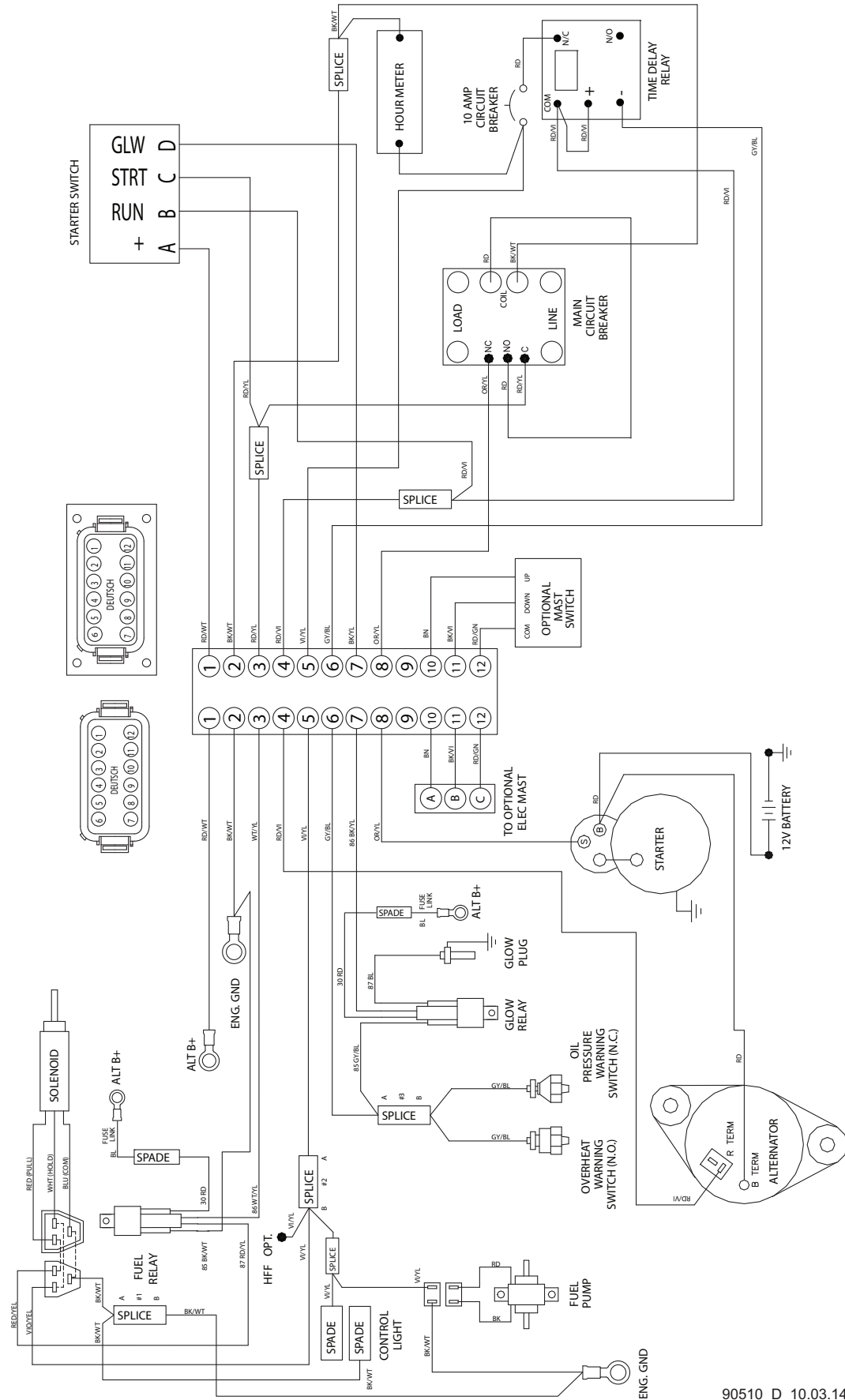

90510_D_10.03.14

DC Wiring Diagram—MLT6SM Power Zone (If Equipped)

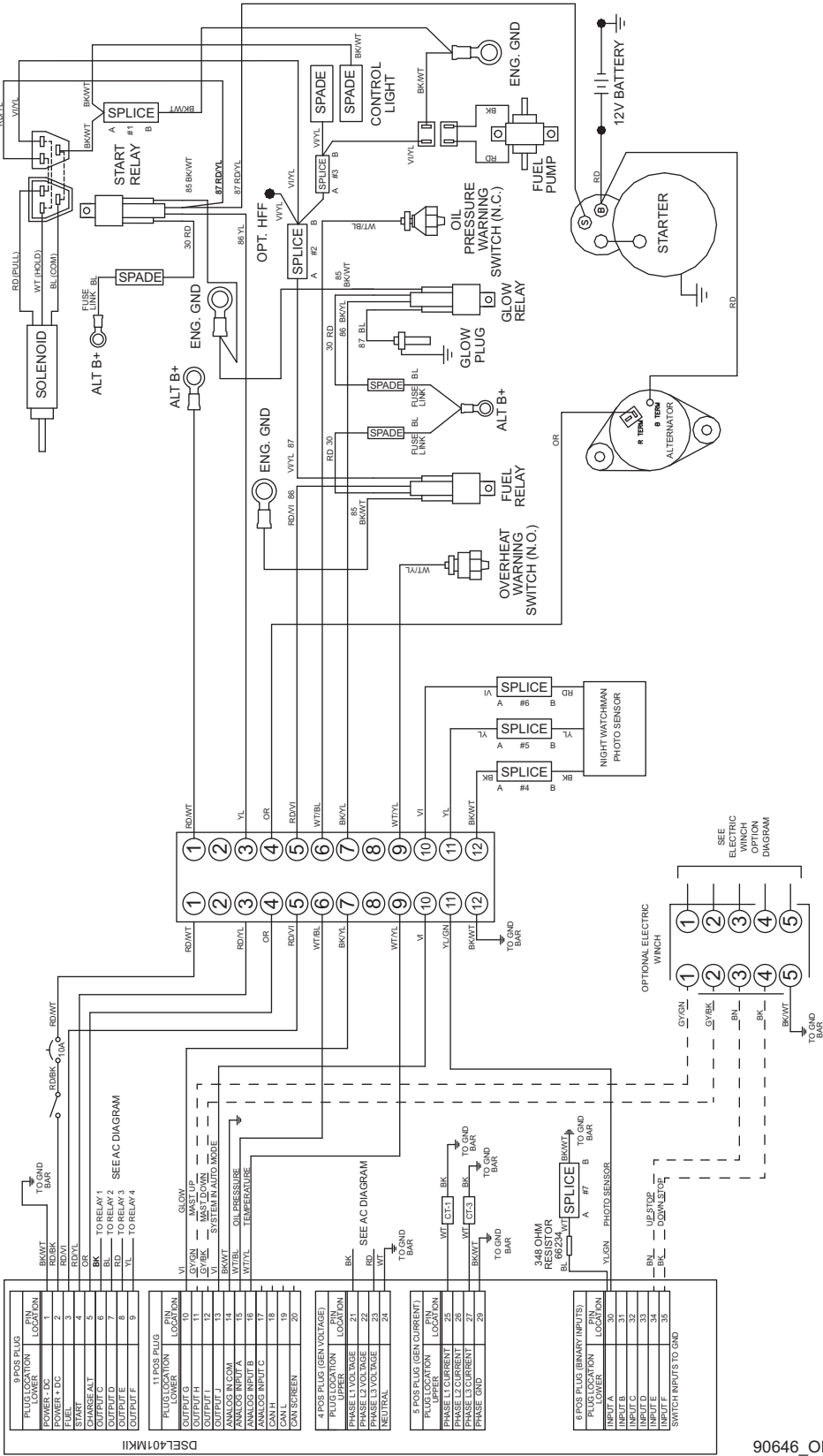

90646_ORG_03.17.15

DC Wiring Diagram—MLT6SK

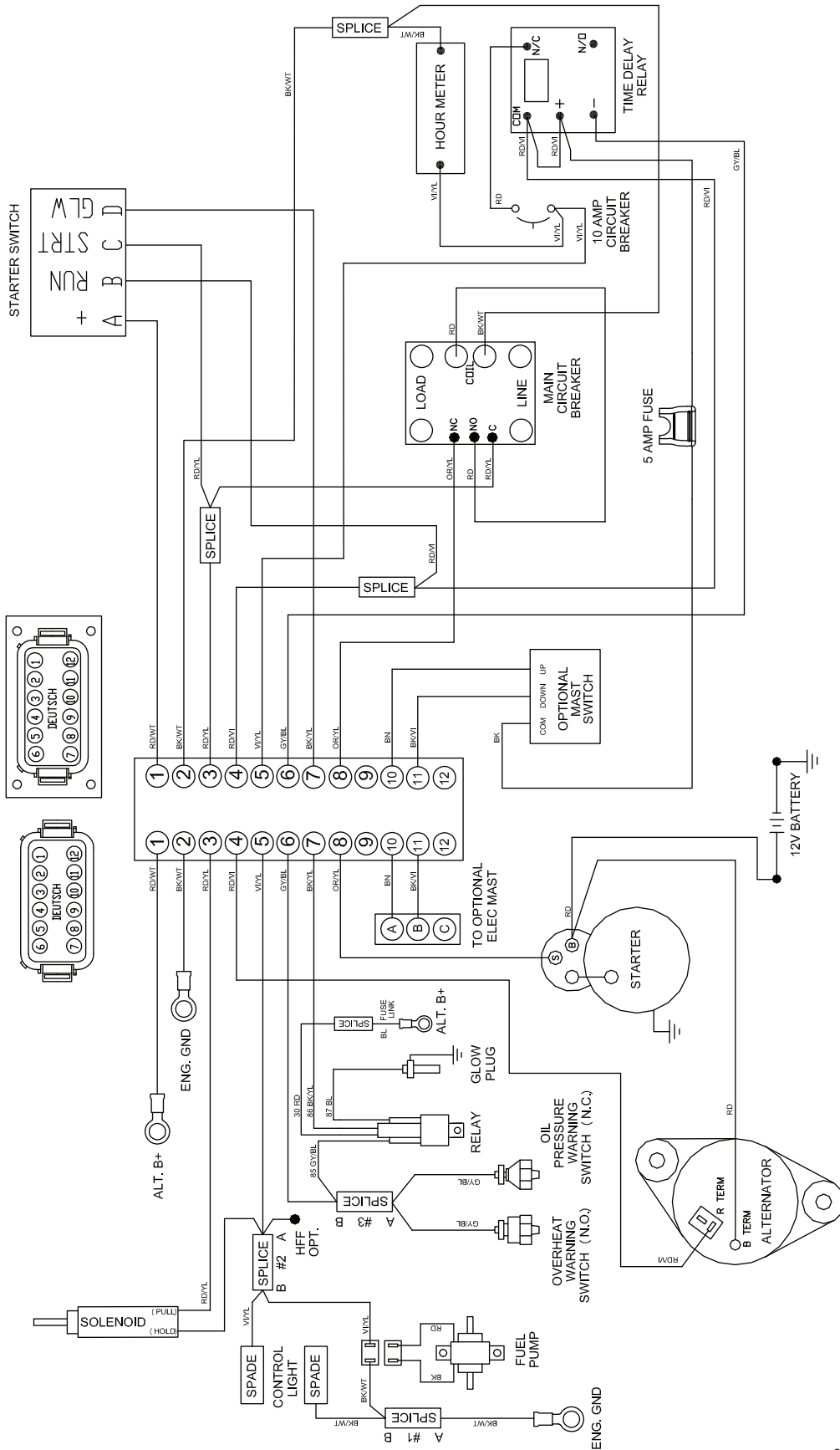

90509_E_6.27.16

DC Wiring Diagram—MLT6SK Power Zone (If Equipped)

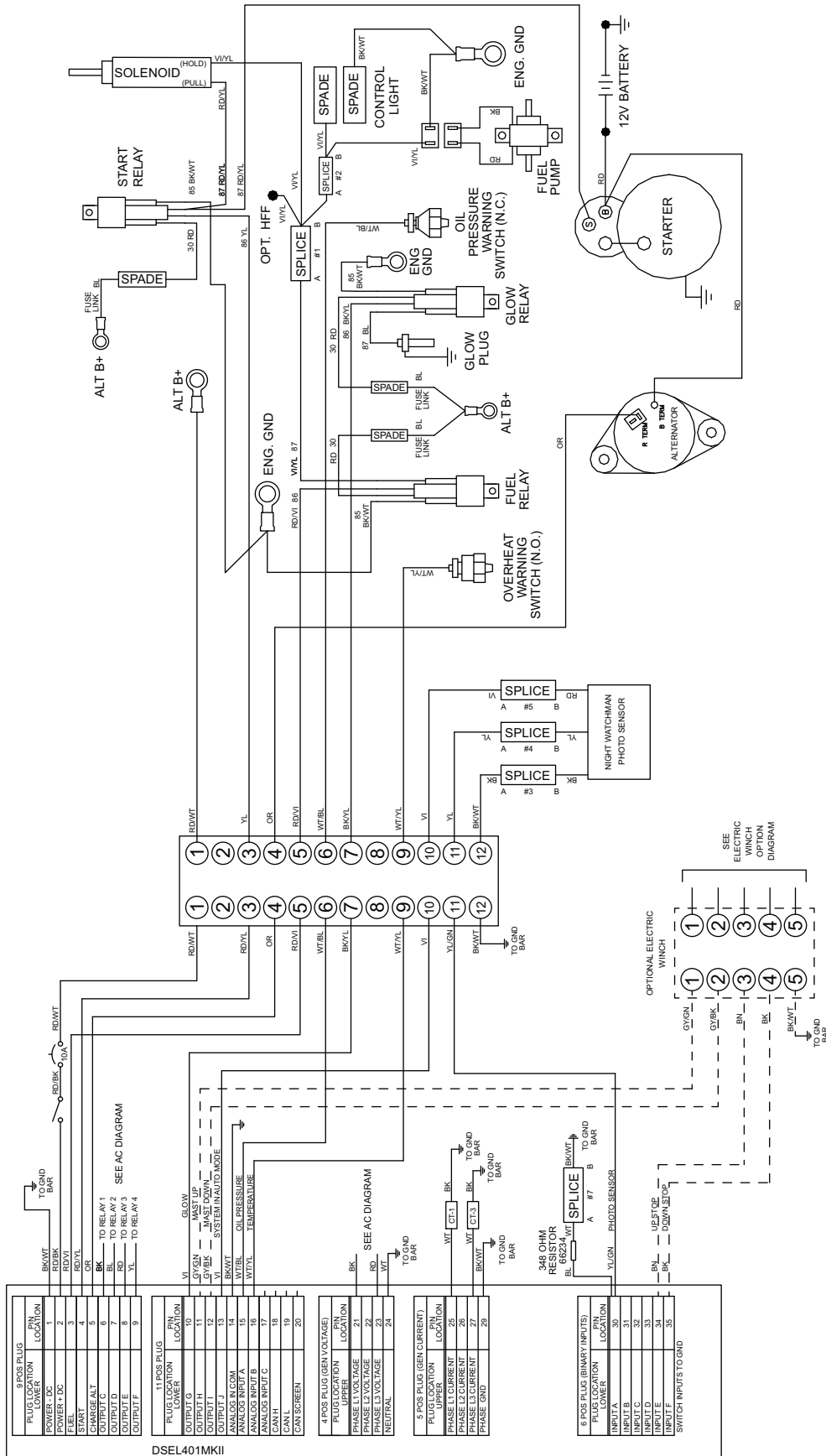

DSEL401MKII

90661_A_09.15.15

DC Wiring Option—Heated Fuel Filter – MLT6SM

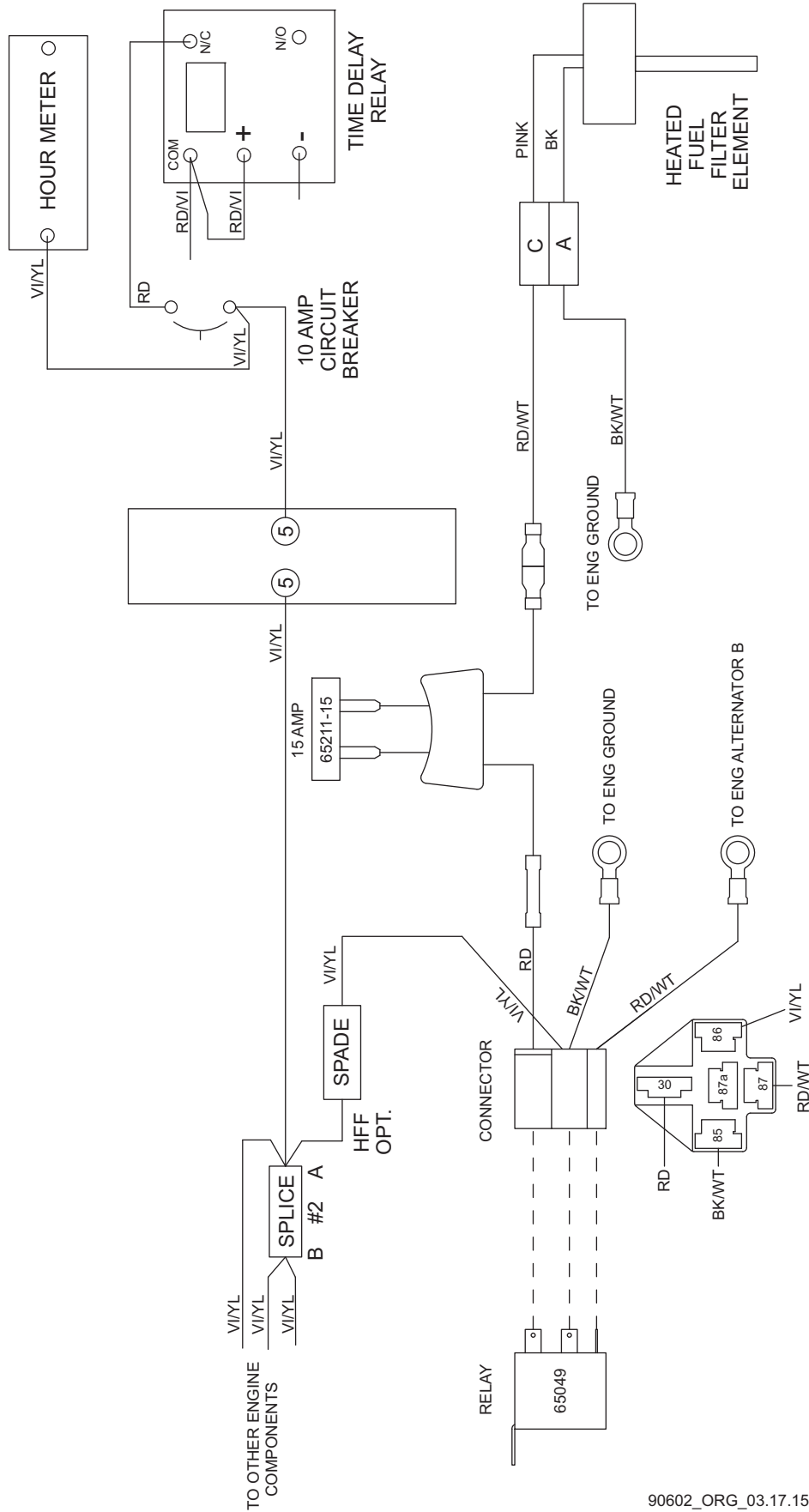

DC Wiring Option—Heated Fuel Filter – MLT6SK

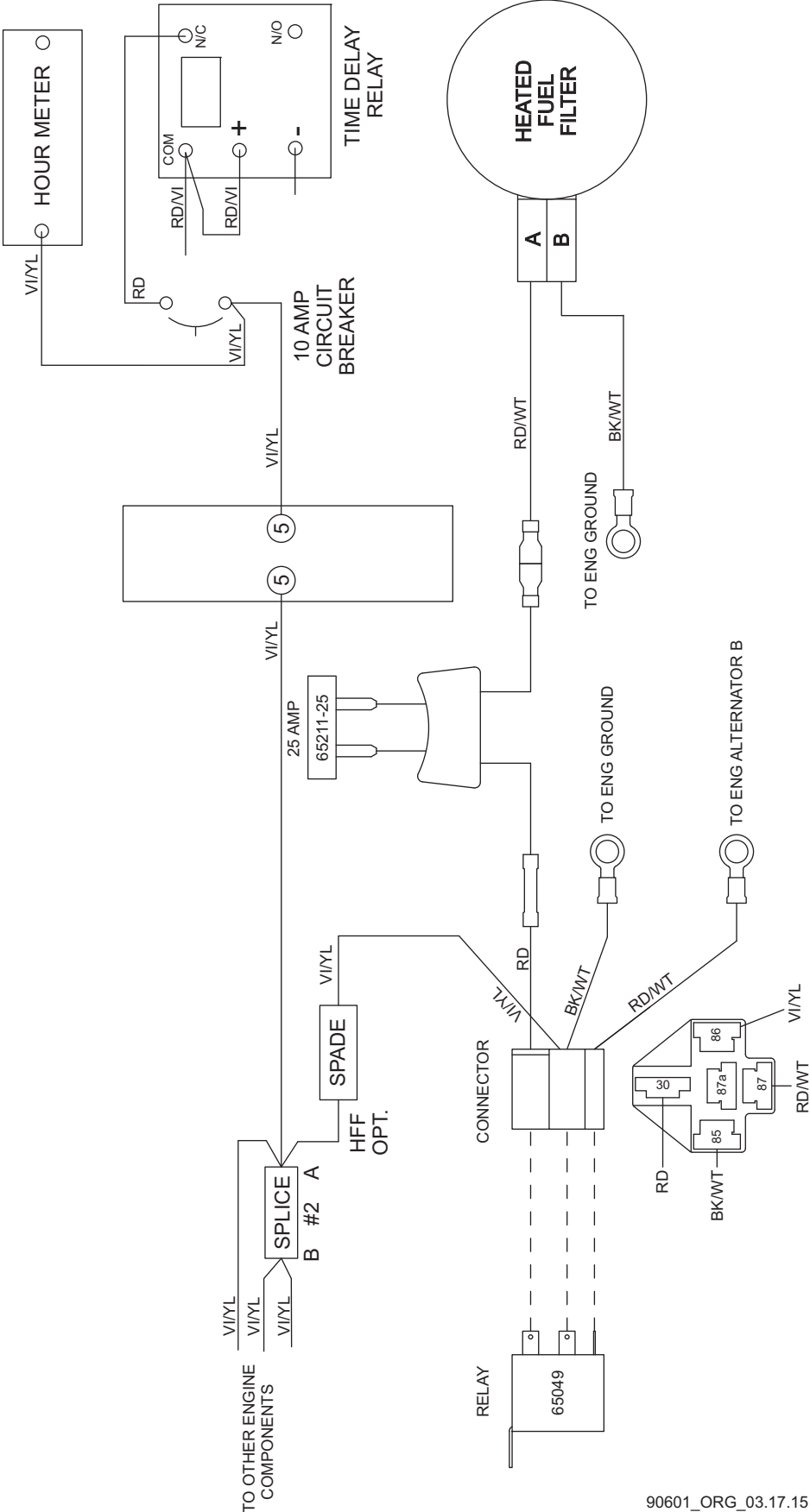

90601_ORG_03.17.15

DC Wiring—Electric Winch Option

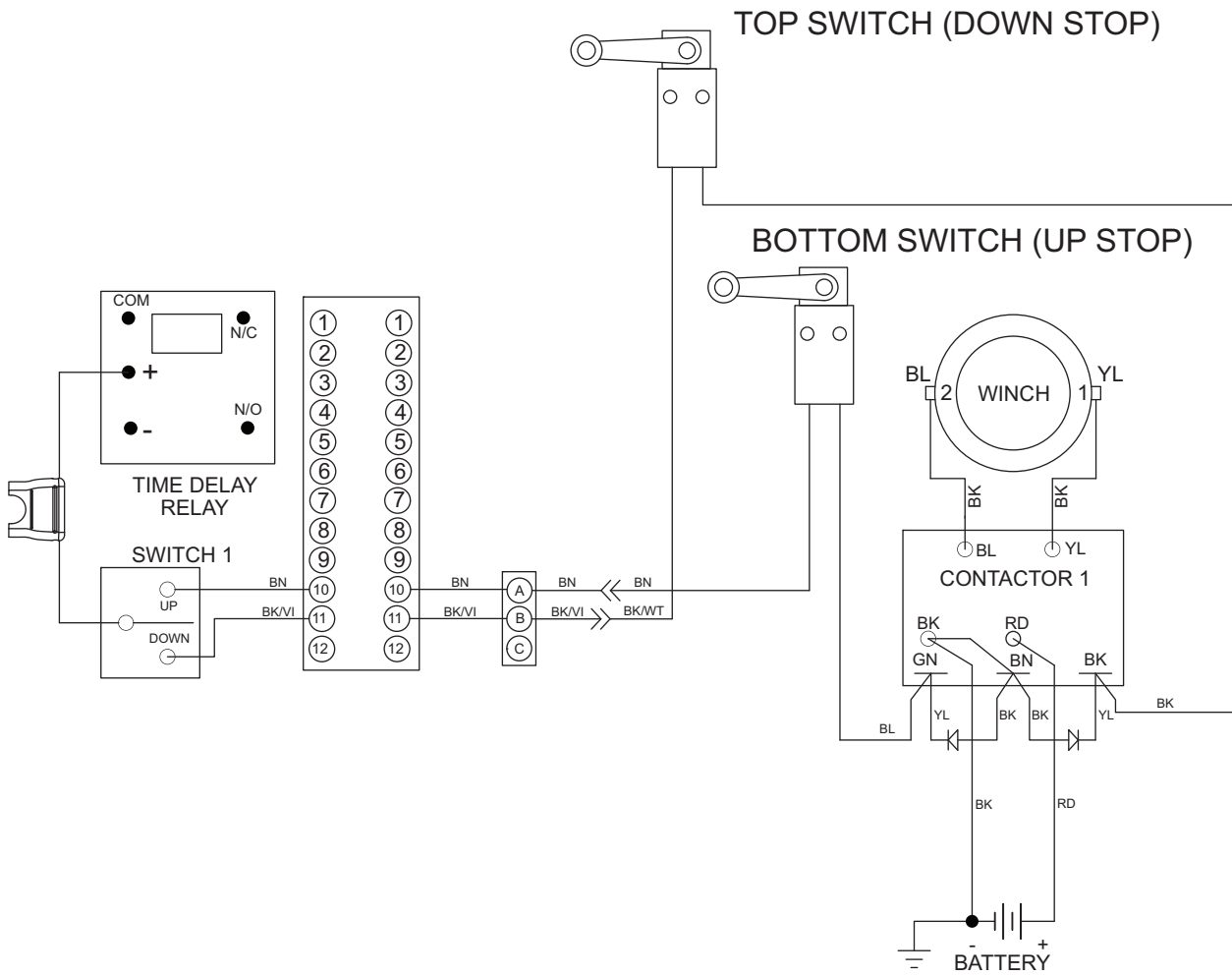

90596_A_07.19.16

Trailer Lights Wiring

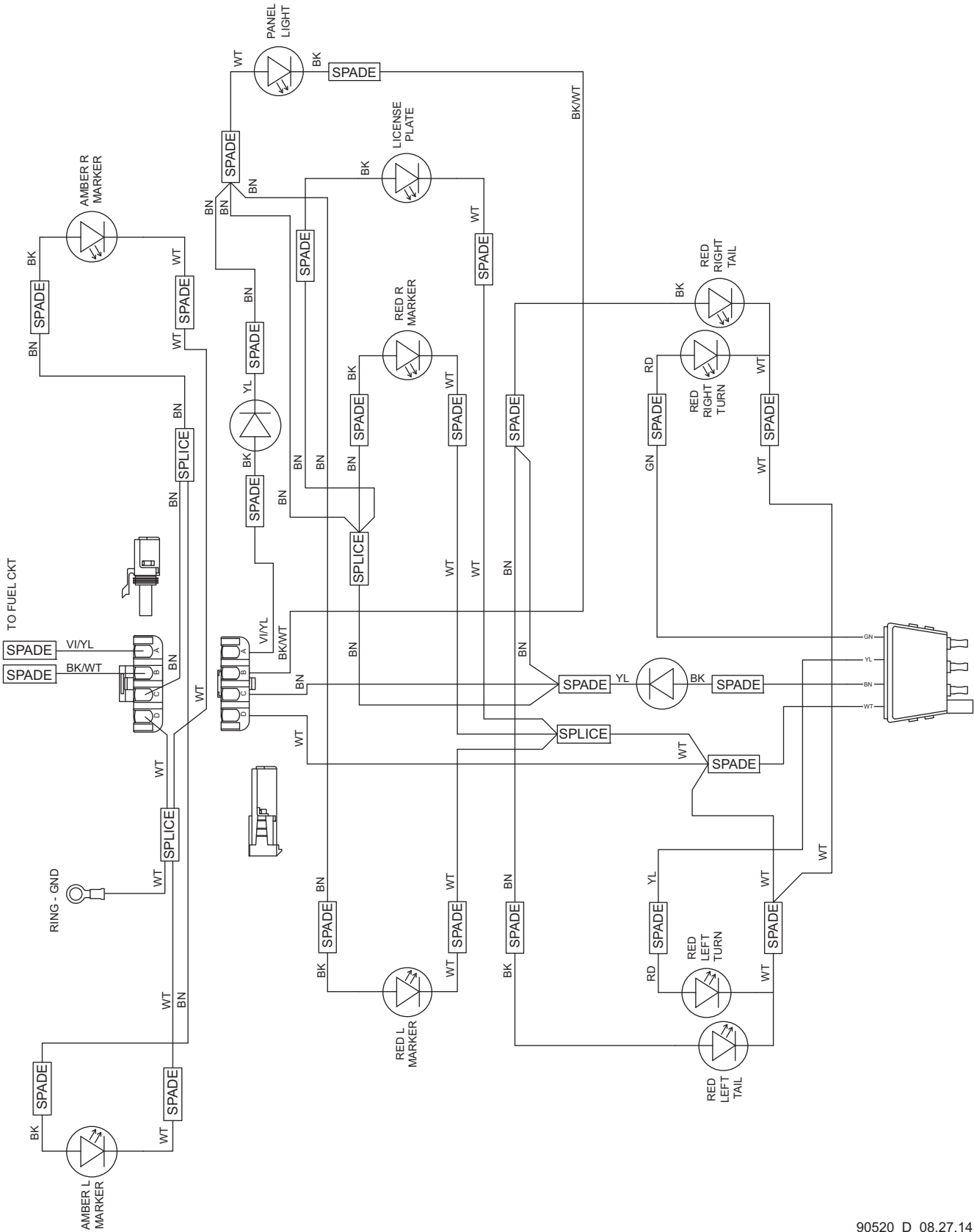

90520_D_08.27.14

Trailer Lights Wiring—Power Zone (If Equipped)

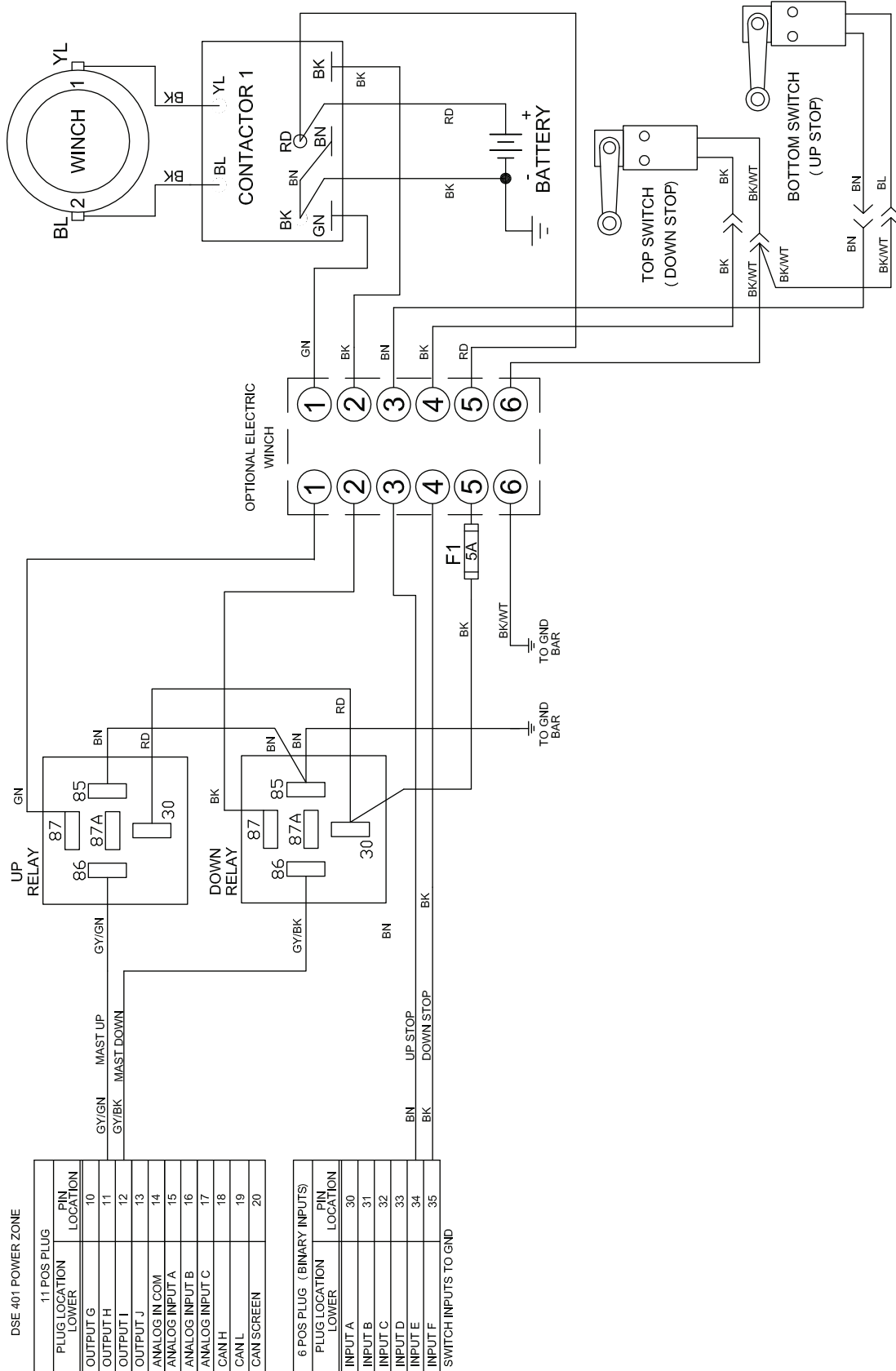

90615_A_12.15.15

This page intentionally left blank.

This page intentionally left blank.

Part No. 17973 Rev. K 03/30/18
©2018 Generac Mobile Products, LLC
All rights reserved.
Specifications are subject to change without notice.
No reproduction allowed in any form without prior written
consent from Generac Mobile Products, LLC.

GENERAC
**MOBILE
PRODUCTS**

Generac Mobile Products, LLC
215 Power Drive, Berlin, WI 54923
GeneracMobileProducts.com | 800-926-9768 | 920-361-4442